

LICENSE AGREEMENT

Static Control Components, Inc. (Static Control) grants this limited license to the person, firm or corporation (hereinafter "User") downloading electronically or by printing this file to use Static Control's copyrighted documents in accordance with the terms of this agreement. If you agree with the terms of the license then you may download this information. If you do not agree with the terms of the license, then you are not authorized to use this information, and any use of it may be in violation of Static Control's copyrights or trademarks.

TRADEMARKS

The Static Control material herein may make reference to its own trademarks, or trademarks of others. Static Control grants a limited license to the User to use Static Control's trademarks in its internal documents and for its internal purposes on the following terms and conditions. Any use of Static Control's trademark must be used in a context which makes it clear that the product reference is a Static Control Components, Inc. product, and not a product from any source. The materials provided to the User may include reference to trademarks of others. Any use of the User makes of these marks should reference the owner of those marks. Nothing in this agreement constitutes any authorization by Static Control to use any of these trademarks in any context.

COPYRIGHTS

Static Control grants a limited license to the User to use the attached copyrighted documents. The permitted use of these documents is limited to internal purposes and needs of the company. The company is prohibited from using these copyrighted documents, or any part of them, including graphic elements, in any materials that are used outside the physical business location of the User. The User is prohibited from using any materials in any documents whether printed or electronic, which are distributed to any third party. The use of these copyrighted documents, or parts of them, including graphic elements, from these documents in marketing material, either print, electronic or web is prohibited. The sale, transfer, copying of these documents or any parts of these documents to any other party is prohibited.

Static Control Components, Inc. retains all rights to its copyrighted documents, and any use of these documents by User should reference Static Control's copyrights, with the notice "copyright Static Control Components, Inc."

Static Control reserves the right to cancel this license on 30-days written notice. All of the User's material incorporating Static Control's copyrighted documents shall be destroyed upon receipt of its notice of termination.

The User may not distribute, share, and otherwise convey the copyrighted documents to any other persons, corporations or individuals.

The User, by use of these documents, acknowledges Static Control's copyright in these materials.

STATIC CONTROL DOES NOT GUARANTEE OR WARRANT DOWNLOADED INFORMATION

The information User is downloading is published by Static Control in "as is" condition "with all faults". Static Control makes no representations or warranties of any kind concerning the quality, safety, or suitability of the downloadable materials, either express or implied, including without limitation any implied warranties of merchantability, fitness for a particular purpose, or non-infringement. Further, Static Control makes no representations or warranties as to the truth, accuracy or completeness of any statements, information or materials concerning items available for download. In no event will Static Control be liable for any indirect, punitive, special, incidental, or consequential damages however they may arise even if Static Control has been previously advised of the possibility of such damages.



Hewlett Packard® LaserJet® 4300/4200 Printer Remanufacturing Instructions



HP4200



HP4300

About the Printers

On Nov. 12, 2002 Hewlett Packard released the LaserJet® 4200 (35ppm) and the LaserJet® 4300 (45ppm) portrait printers. Marketed as the next standard in monochrome laser printing, both the HP4300 and 4200 replaced the 25 ppm HP4100 (March 2001), which was discontinued in January 2003.

The 4300 and 4200 have a first page out time of under 9 seconds, an improvement of 3 seconds over that of the 4100. Other improvements included advanced toner formulation, increased memory and expanded paper handling options, all while maintaining approximately the same acquisition price as the 4100.

The 4300 and 4200 are based on the same engine, and they both appear to be identical on the exterior (as well as quite similar to the HP4100). Both feature an updated version of HP's Chai Java Embedded Printer Web server, and additional data functions have been added to the supplies status page. The organization of the page has been modified so that information important to the user is easier to locate, and it now includes a *First Install Date* and a *Last Used Date*.

There are six configurations of each model, which add one or two features with each step up. They include the base unit, the network-ready "n" with additional memory, the "tn" with one additional 500-sheet input tray, the "dtn" with an added duplexing unit, the "dtns" with a stacker and another 500 sheet tray, and the "dtnsl" with a stapler added.

About the Cartridges

The toner cartridges for each machine are basically the same design, with the 4300's hopper being larger to accommodate the increased toner load. The design of the 4300's waste bin and hopper includes molded features which act as keys, preventing installation of the cartridges in the 4200 series printers, and vice versa.

The exterior designs of both the 4300 and 4200 cartridges look very much like that of the 4100, including the presence of a smart chip. However, the chip is physically different from that on the HP4100, being a "direct contact" type. It is a non-RF based ASIC chip, having two electrical contacts that make a physical connection with the printer when the cartridge is installed. But like the 4100, if this chip is missing the printer will give a "non-HP cartridge installed" error, and the toner level information will not be available.

Internally the 4300 and 4200 cartridges are nearly identical, with minor differences that affect remanufacturing only slightly. The components are the same for both cartridges, with the exception of the electronic chips.

Key Points

- Externally both the hoppers and waste bins differ in size and shape, with the HP4300 being larger, and having "slots" molded into the body that act as keys to prevent cross-printer compatibility.
- Internally the components are the same for both cartridges. However, the wiper blade of the HP4300 lies beneath a narrow retaining ledge molded into the waste bin housing. This ledge must be cut away before the wiper blade can be removed.
- Instead of a conventional wiper blade sealing foam along the back edge of the blade, there is a line of hot melt foam material that is sticky to the touch. Though inconvenient to remove and clean from the cartridge, it is not a major issue.

Table of Contents

About the Printers	1
About the Cartridges	1
Tools & Supplies You Will Need	3
Compressed Air; Use of	3
Isopropyl Alcohol, Use of	3
Illustration, 4300 Hopper Section	4
Illustration, 4300 Mag Roller Section	5
Illustration, 4300 Drum Section	6
Illustration, 4200 Hopper Section	7
Illustration, 4200 Mag Roller Section	8
Illustration, 4200 Drum Section	9
Cartridge, Separation	10
Hopper, Disassembly	13
Hopper, Reassembly	17
Waste Bin, Disassembly	21
Waste Bin, Reassembly	26
Cartridge, Reassembly	28

www.scc-inc.com/imaging/Imaging.htm

Get the latest information
on the web at Static Control's
Online Engine Center at
www.scc-inc.com/Engine



System Support Series™
Documents are available
on our Web site in
Adobe® Acrobat® format.

If you need additional
information or technical
assistance, please contact your
Static Support Team.

1.800.488.2426 (USA)
919.774.3808 (Int'l)
+44 (0) 118 923 8800 (UK)
info@scc-inc.com (USA e-mail)
info@scceurope.co.uk (UK e-mail)
www.scc-inc.com/imaging/Imaging.htm

Continued on page 2

Version 4
August 2004

Continued from page 1

- Static Control offers a sealing solution to replace the OEM hot melt foam sealing material. A foam seal is used in the 4200 and adhesive caulk is used in the 4300.
- The “no shake” design incorporates two toner agitators within the toner reservoir, and one behind the mag roller.
- The mag roller saddles are magnetic, and have sealing foams beneath them that are prone to becoming impregnated with toner. These foams should be inspected and replaced as needed (refer to SSS™ 534 for instructions).
- The contact end plate is held in place with three plastic welds which are easily removed. To reattach the end plate, however, the weld material must be removed. Static Control offers a kit that includes a drill template, bit, and screws for accurate alignment and installation of the contact end plate.

- The hopper cap is a one-piece, molded design similar to that on the HP9000. Removal damages the cap, resulting in toner leakage if re-used. Static Control's HP9000 replacement hopper cap also fits the 4200 and 4300 cartridges, preventing toner leakage.
- Unlike the HP4100, the smart chip is a non-RF based, direct contact type, with two electrical contacts that make a physical connection with the printer when the cartridge is installed. But like the 4100, if this chip is missing the printer will give a “non-HP cartridge installed” error, and the toner level information will not be available.
- There is a sensor on the cartridge exterior that recognizes the presence of a seal on a new cartridge. If the seal is not removed, the control panel message “54.1 Remove Sealing Tape From Toner Cartridge” will be displayed and the printer will not operate.

The alignment of the contact end plate is critical. An error message will be displayed and the printer will not function if the end plate is not properly aligned.

Printer Information:	Hewlett Packard® 4200 Series	Hewlett Packard® 4300 Series
Introductory Price (OEM):	\$1,099 to \$2,446	\$1,399 to \$2,755
Date of Printer Introduction:	Nov. 2002	Nov. 2002
First Page Out:	<9 seconds	<9 seconds
Processor:	300MHz	350MHz
Print Speed (pages per minute):	35ppm (letter)	45ppm (letter)
Duty Cycle (pages per month):	150,000	200,000
Print Resolution (dpi):	1200x1200 (REt)	1200x1200 (REt)

Cartridge Information:	Hewlett Packard® 4200 Series	Hewlett Packard® 4300 Series
Cartridge Part Number (OEM):	Q1338A	Q1339A
Street Price*:	\$222	\$295
Wholesale Price*:	\$123	\$164
OEM Rated Page Yield:	12,000@ 5%	18, 000@ 5%

**Prices as of April 2003*

Cartridge Compatibility**:	
Q1338A	Q1339A
4200	4300
4200n	4300n
4200tn	4300tn
4200dtn	4300dtn
4200dtns	4300dtns
4200dtnsl	4300dtnsl

****Cartridge components are interchangeable between cartridges, but cartridges are keyed to prevent cross-model compatibility.**



Tools and Supplies You Will Need

Tools and Supplies

Items Recommended for Basic Remanufacturing:

- Protective Eyewear
- Phillips Screwdriver
- Small Flat-blade Screwdriver
- Shallow trough for dipping the wiper blade
- 91-99% Isopropyl Alcohol
- Conductive Cartridge LubricantCONCLUBE
- Adhesive Caulk (HP4300 only)ADHCAULK
- Cotton-Tipped ApplicatorQ-TIP
- Flush Cutting Pliers (Side Cutters)FCPLIER
- Hook ToolHTOOL
- Hopper Cap9KHCAP
- Mag Roller Journal Removal PressHP43MRPRESS-R
- Mag Roller Journal Insertion PressHP43MRPRESS-I
- Hopper Fixture:
 - HP4200HP42HJIG
 - HP4300HP43HJIG
- Ionized Compressed AirAIRGUNSET
- Kynar® Lubricating PowderKPOW
- Lint-free Cleaning ClothLFCLOTH
- Felt/Foam Scraper ToolFSTOOL
- OPC Drum (with gears)Call for availability
- Toner qualified for the HP4200 & 4300 systems:
 -Call for availability

For Doctor Blade Replacement:

- Doctor BladeHP43DBLADE

For Electronic Chip Replacement:

- HP4200/4300 Replacement ChipCall for availability
- SSS™ #527 “HP4200/4300 Replacement Chip” instructions

For Hopper Splitting and Sealing

- Splitter ToolHP85SPLITOOL-K
- Foam-Type RapidSeal™ with TabHP43FTRSPK
- Adhesive Rail ClipHP43ADHRCLIP
- HP4300/4200 Short Locking Rails (3)CSHP43-500
- SSS™ #493 “HP4300/4200 Splitting and Sealing Instructions”
- SSS™ #522 “Adhesive Rail Clip and Short Rails” instructions

For Wiper Blade Removal & Replacement:

- Rotary tool with flex shaft attachment (HP4300 Only)
- HP4300/4200 Wiper Blade Ledge Tool(HP43WBTOOL)
- Wiper BladesHP43BLADE
- Wiper Blade Sealing Foams
 - HP4200HP42WBSFOAM
- SSS™ #441 “HP8500 & HP4300/4200 Wiper Blade End Foams
- SSS™ #501 “HP4300/4200 Wiper Blade Sealing Foam
- SSS™ #533 “HP4300 Wiper Blade Ledge Tool” instructions

For Contact End Plate Reattachment:

- End Plate KitHP43EPLATEKIT-2
- Electric Drill (capable of accepting a 5/16 inch [7.93 mm] bit)
- Rotary tool with flex shaft, sanding disc
- SSS™ #590 “HP4300/4200 Contact End Plate Kit” instructions

For more information about other replacement components available for these cartridges, contact a member of your Static Support Team, or visit our Web site at www.scc-inc.com/imaging/Imaging.htm.

Use of Isopropyl Alcohol

For best results, we recommend using ONLY 91-99% for cleaning as directed in these instructions. 91% isopropyl alcohol is available at most major drug stores; 99% isopropyl alcohol is available through distributors of chemical products. Follow the alcohol manufacturer's safety instructions.

Use of Compressed Air

As of April 28, 1971, the Occupational Safety & Health Administration (OSHA) Standard, 29 CFR 1910.242 paragraphs a & b for general industry requires effective chip guarding and personal protective equipment (PPE) when using compressed air. When cleaning residual toner particles from cartridges using a compressed air system, you must use air nozzles meeting OSHA requirements. Air nozzles that regulate air pressure to a maximum of 30 psi comply with this standard. Refer to the OSHA publication for any updates or changes that have occurred since the date noted above.

HEWLETT-PACKARD® 4300

TONER HOPPER SECTION

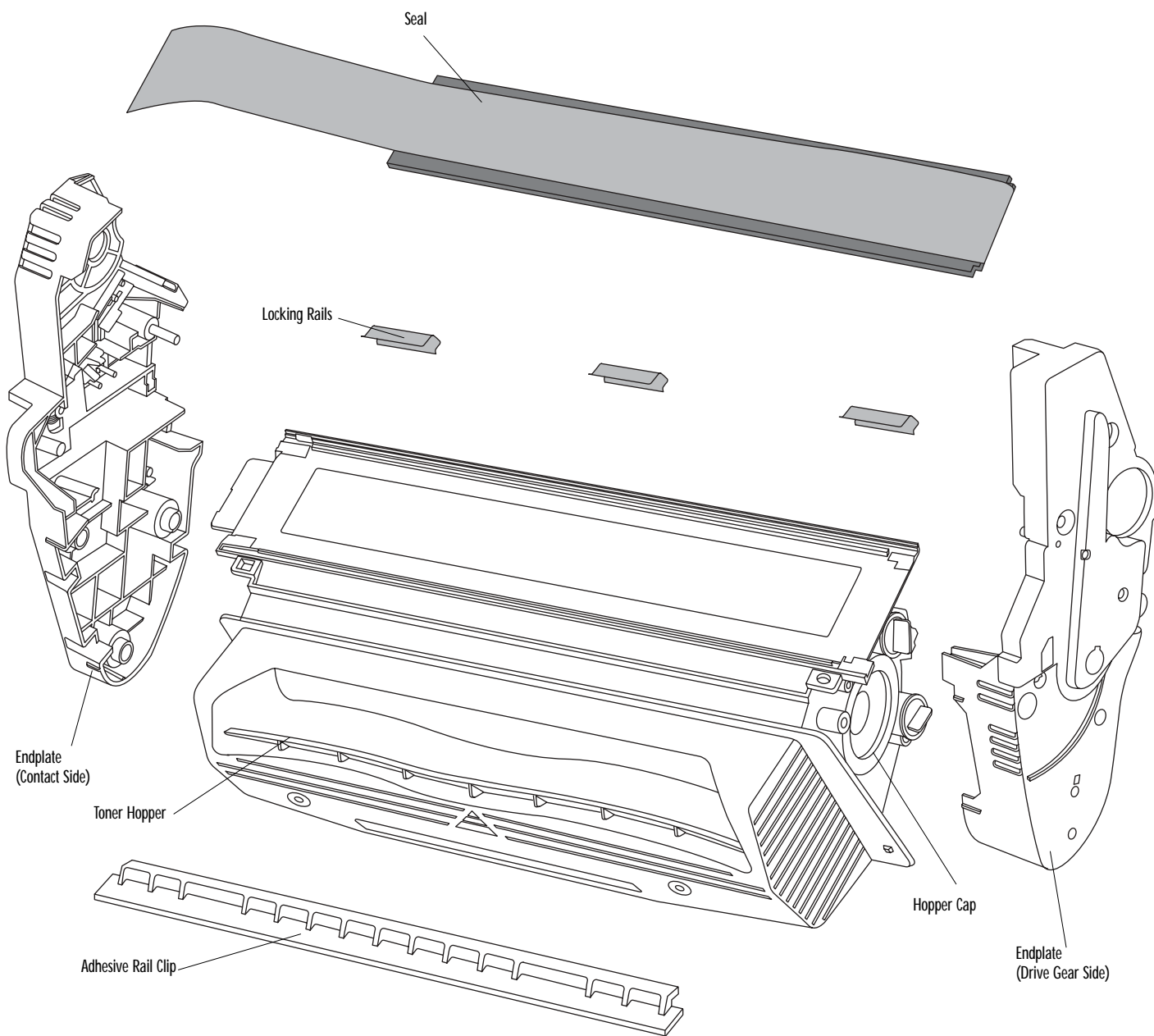

HEWLETT-PACKARD® 4300

MAG ROLLER SECTION

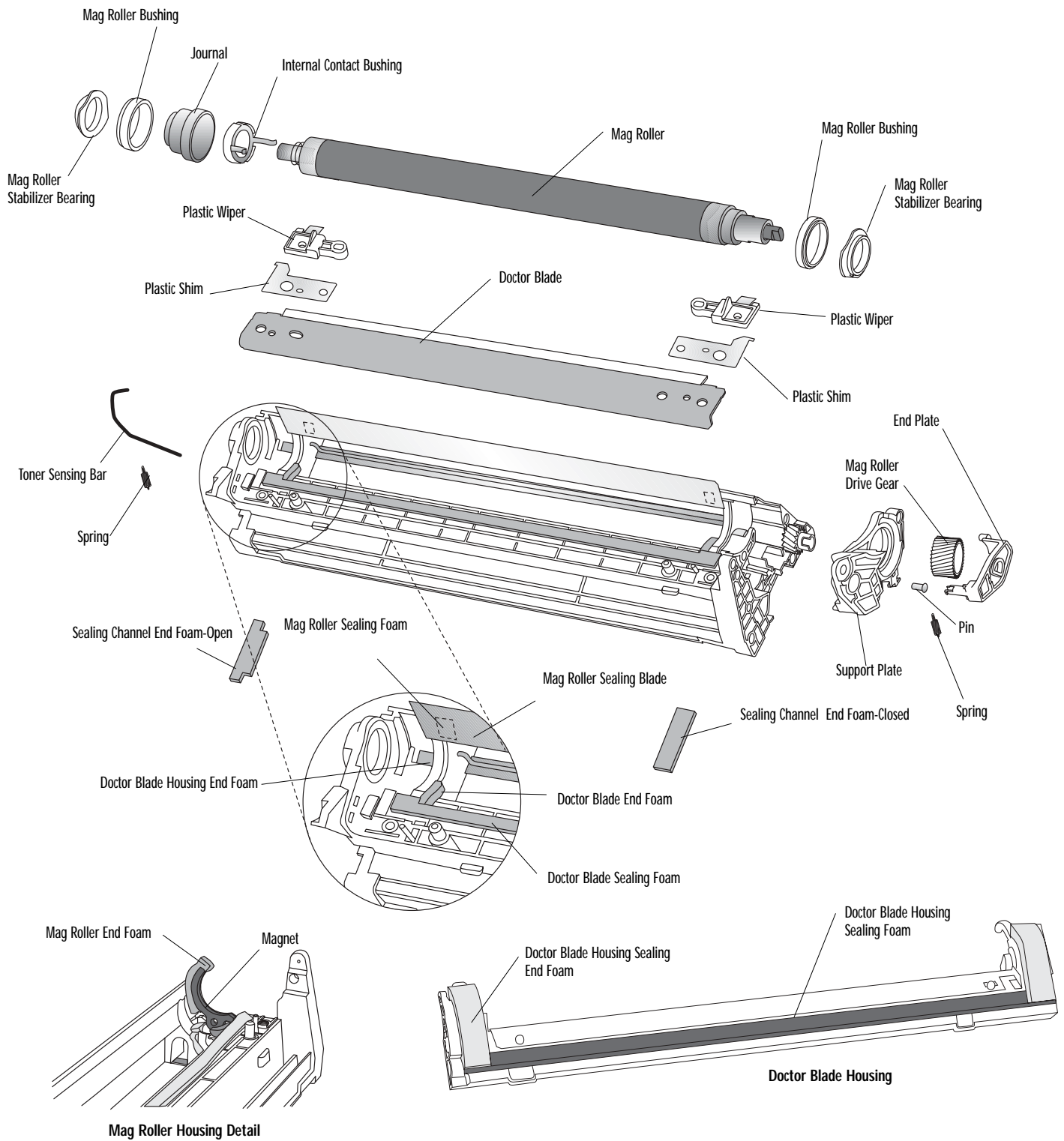

HEWLETT-PACKARD® 4300

DRUM SECTION

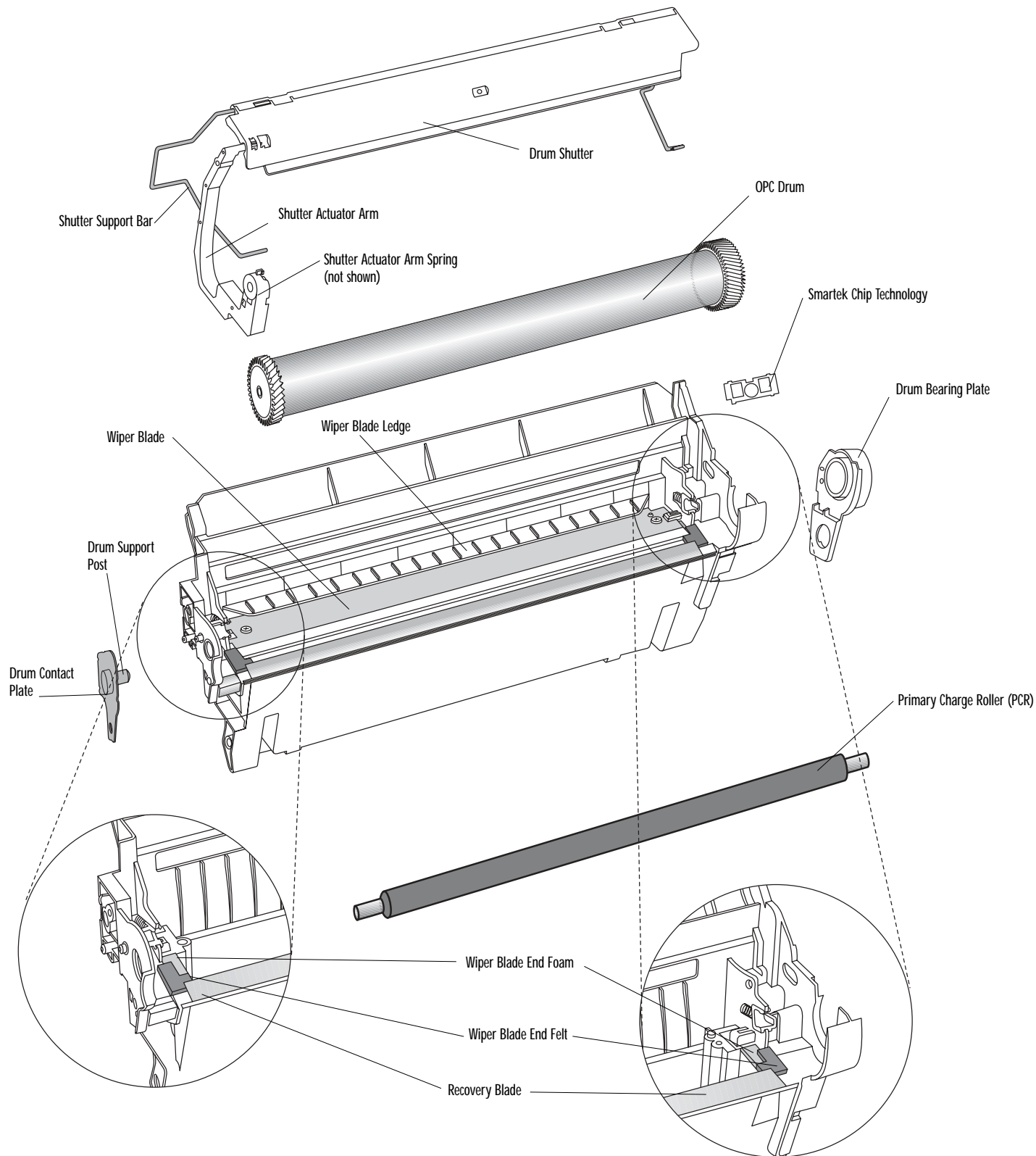

HEWLETT-PACKARD® 4200

TONER HOPPER SECTION

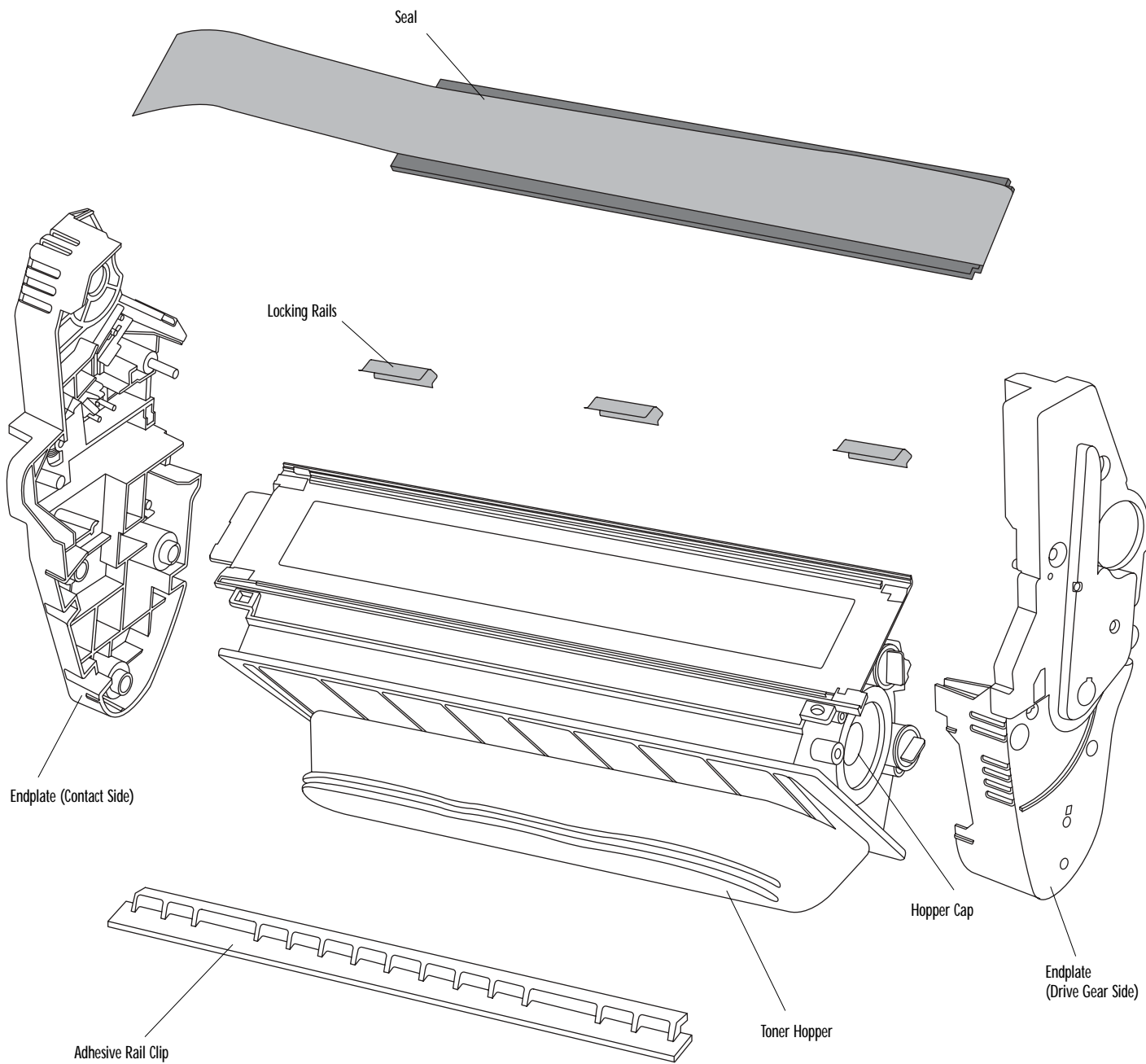

HEWLETT-PACKARD® 4200

MAG ROLLER SECTION

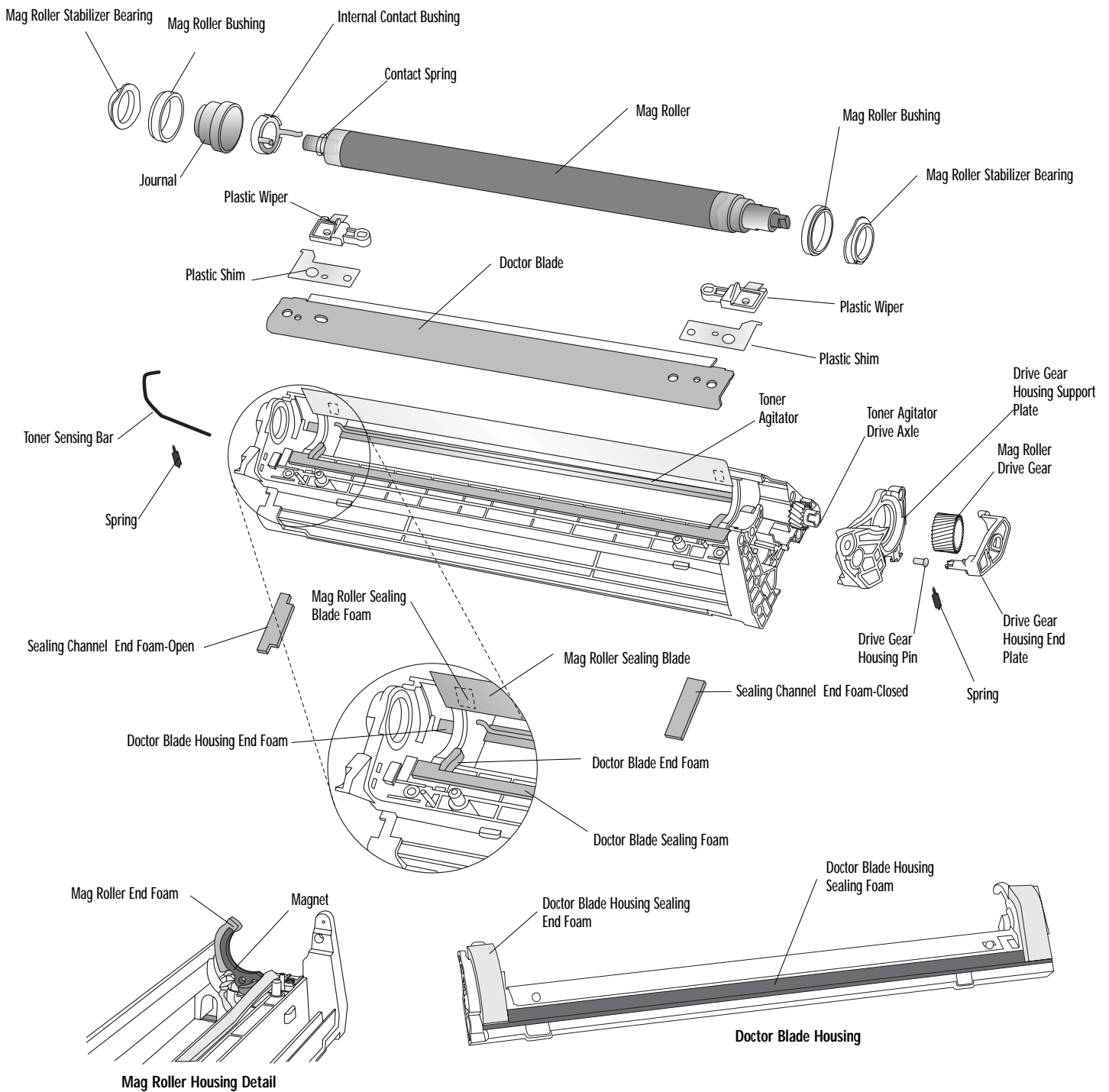

HEWLETT-PACKARD® 4200

DRUM SECTION

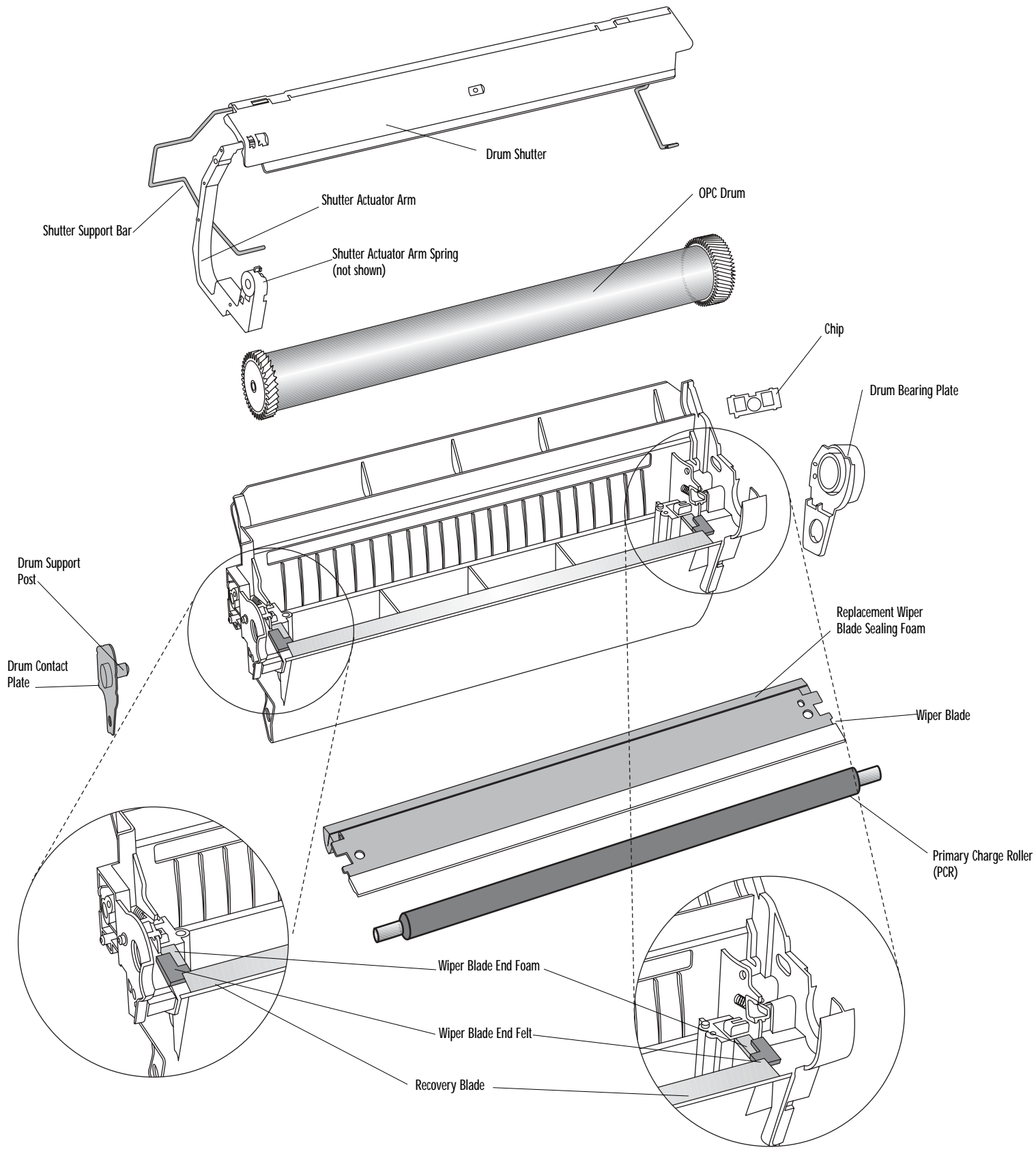

Separation of the Cartridge

Using these instructions: Remanufacturing steps for the HP4300 and 4200 are identical, except for the first time removal of the HP4300 wiper blade. The HP4300 cartridge is shown in all photos and illustrations, except where they differ from the HP4200. For those steps, instructions for both cartridges are detailed with photos and/or illustrations of each.

NOTE Use cartridge holding fixture when working with the HP4300 and 4200 cartridges.

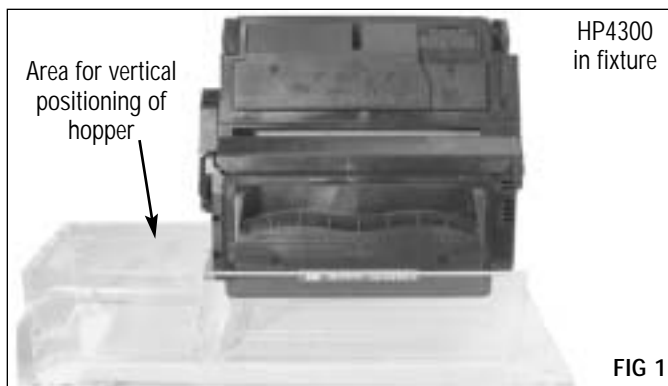

1. Remove the drum shutter

Fully open the shutter and carefully pull the end of the drum shutter support bar out of the drive gear-side end plate (FIG 2).



While holding the drum shutter in the open position, locate the drum shutter actuator arm spring on the contact (left) side of the cartridge (FIG 3).

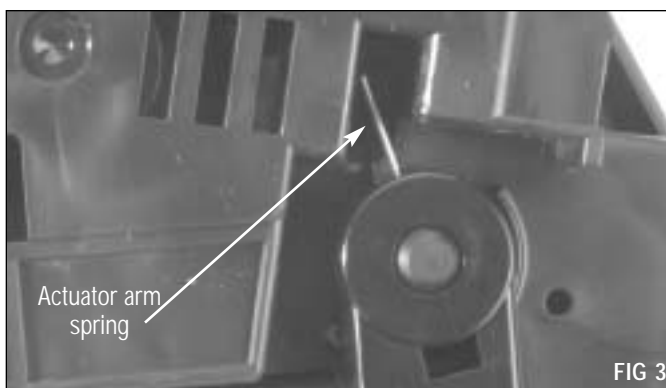

Open the shutter approximately one inch and insert a hook tool. Carefully lift the end of the actuator arm spring up. Let it drop onto the ledge on the spring cover and remove the tool (FIG 4). This will lock the spring in place on the actuator arm, preventing it from popping off when the shutter is removed.

NOTE If the drum shutter actuator arm spring is not secured in this manner it will fall onto your work surface when the shutter is removed. This spring is necessary for proper operation of the cartridge. Take care not to damage or misplace this spring.

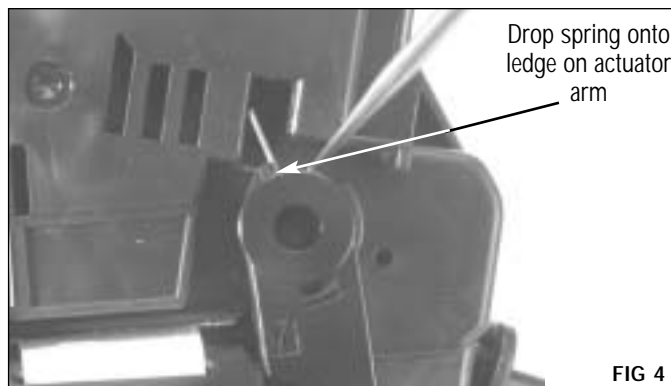

While looking at the contact end plate, close the shutter just enough to allow the actuator arm spring to clear the end plate (FIG 5).

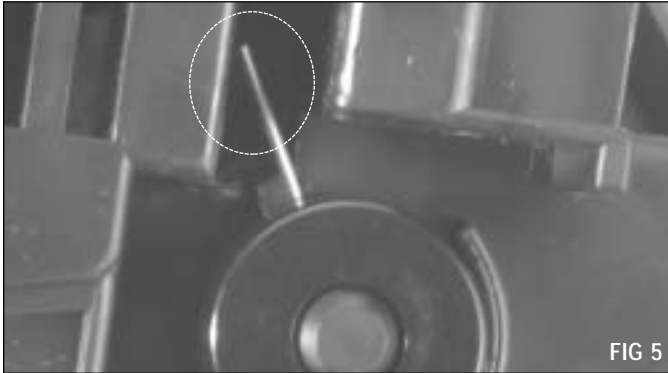

Use the hook tool to help pull the actuator arm away from the cartridge (FIG 6). While supporting the shutter to prevent bending, use the hook tool to pull the drum shutter support bar from the end plate.



NOTE It is not necessary to remove the actuator arm from the shutter.

2. Remove the drive gear end plate

Using a Phillips screwdriver, remove the four screws that secure the **drive gear-side** end plate (FIG 7).

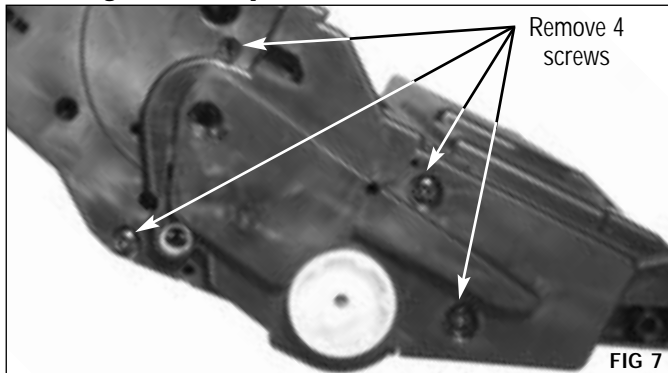

Carefully remove the end plate from the cartridge housing (FIG 8).

NOTE Several gears are housed within this end plate. They should be secure and not easily dislodged. However, care should be taken when moving and cleaning to insure the presence and proper placement of all gears.

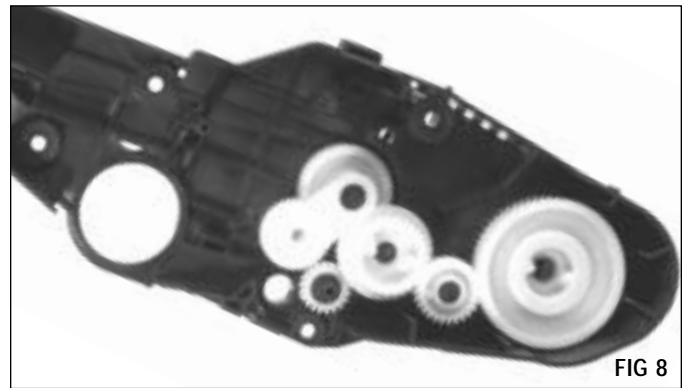

3. Remove the contact end plate

Remove the two screws that secure the **contact** end plate. Do not remove the drum axle screw at this time (FIG 9).

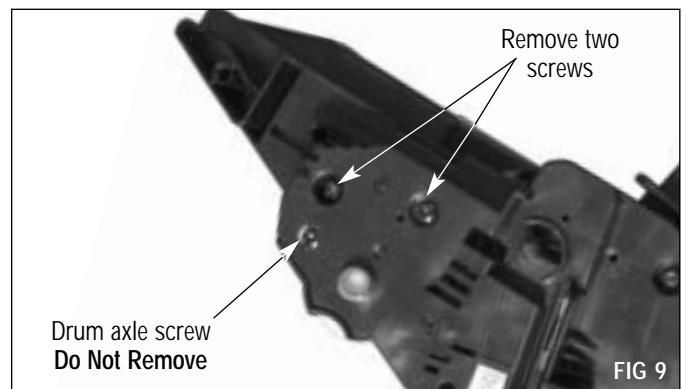

Caution:

There are three welds that secure the lower half of the contact end plate (FIG 10). The use of protective eyewear is strongly recommended when removing these welds. If adequate eye protection is not worn, serious eye injury may result.

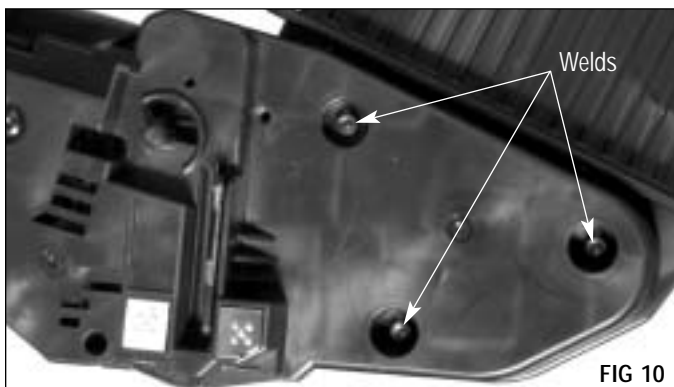

Insert the tip of a medium-size flat-blade screwdriver at the base of the first weld and carefully pry up. The weld should pop off at the base. Continue with the remaining two welds (FIG 11).

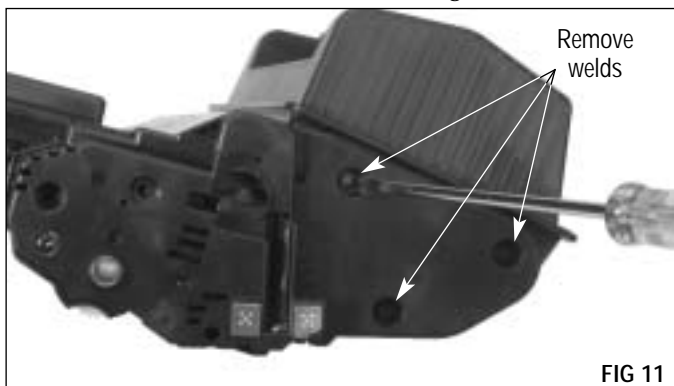

Using the screwdriver in the locations shown, and in the order shown, break away the lower portion of the welds and remove the end plate (FIGs 12a through 12c).

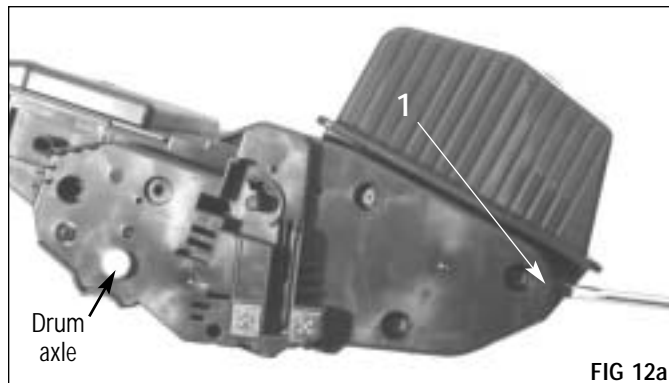

NOTE The drum axle has a snug friction fit. To remove the end plate, you may need to rock the plate back and forth slightly as you pull it away from the cartridge housing.

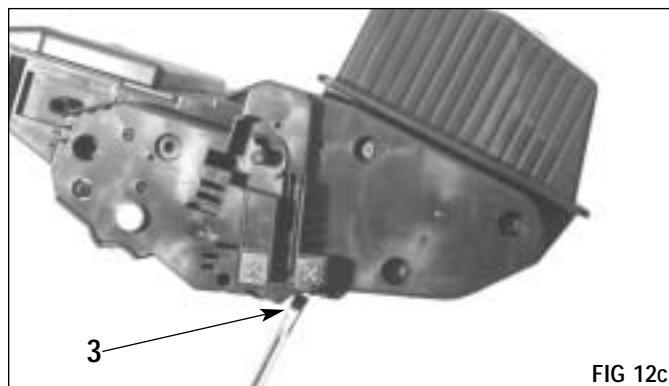
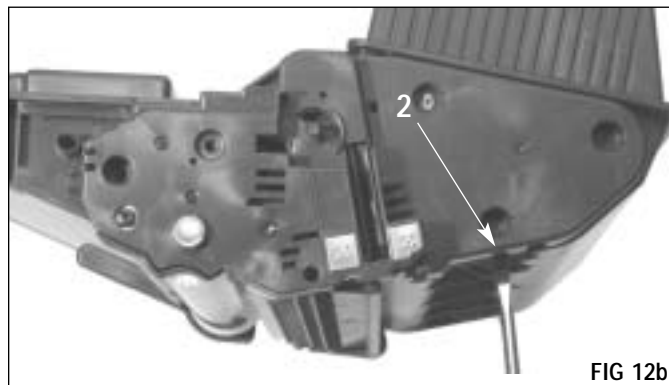

Lift the waste bin section off the hopper/mag section and set the waste bin aside, taking care to protect the drum from light and impact damage.



Disassembly of the Hopper Section

1. Remove the mag roller drive gear housing end plate (drive side)

NOTE Oils from your skin will adhere to the mag roller, which can cause print defects. If you plan to reuse the roller, be sure to use gloves or other protective materials when working near the mag roller.

Remove the mag roller drive gear housing end plate (FIG 13).

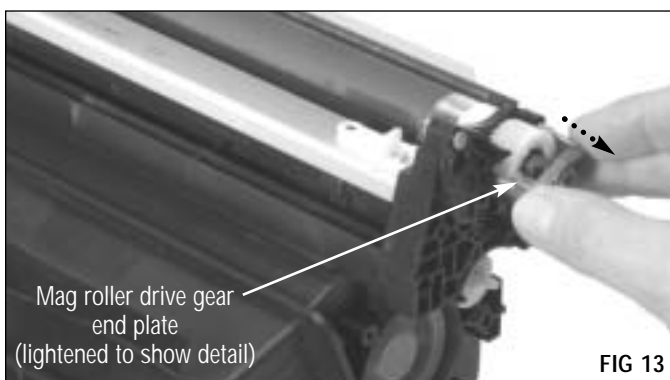

Remove the mag roller drive gear and the mag roller support plate pin. **DO NOT** remove the toner agitator drive gear (FIG 14).

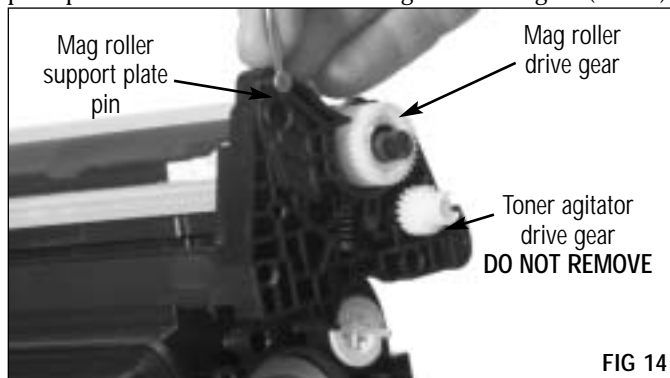

Remove the mag roller support plate spring and the Phillips screw that secures the mag roller drive gear housing support plate (FIG 15).

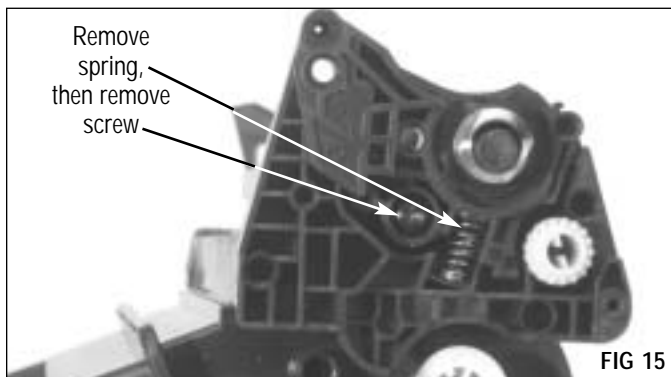

Remove the mag roller drive gear housing support plate (FIG 16).

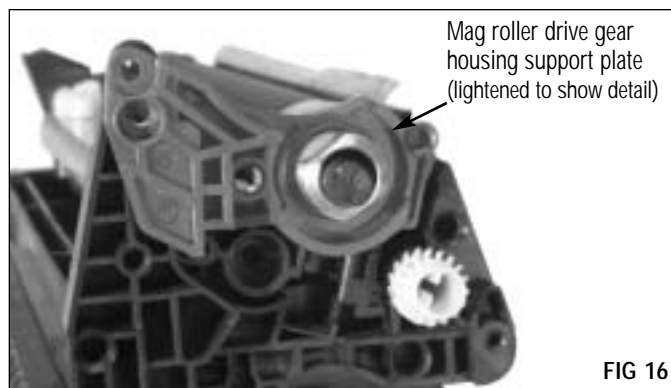

NOTE Remove the mag roller bearing and put it in a safe place for future use, as the cartridge will not operate properly without it (FIG 17).

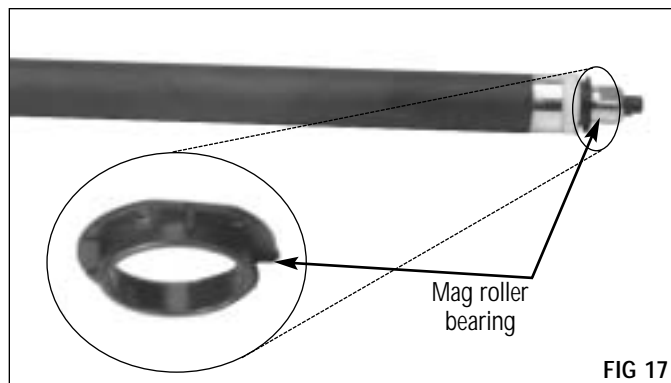

2. Remove the contact end mag roller end plate (contact side)

Remove the toner low sensor bar (electrical contact pin) from the contact end of the mag roller assembly (FIG 18).

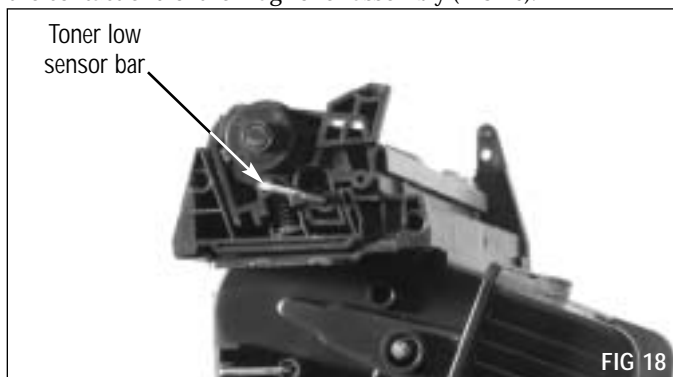

Remove the spring and the Phillips screw that secures the mag roller end plate (FIG 19).

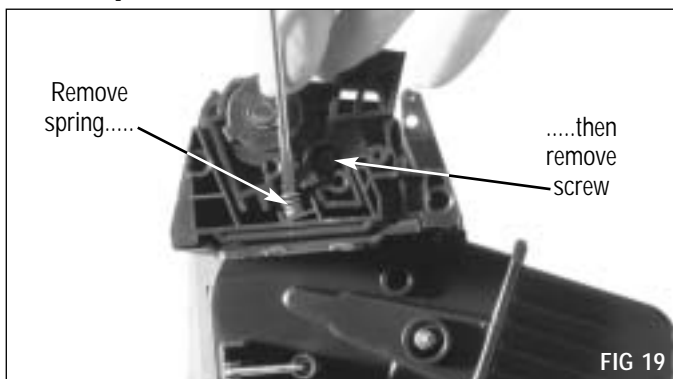

Remove the mag roller end plate (FIG 20).

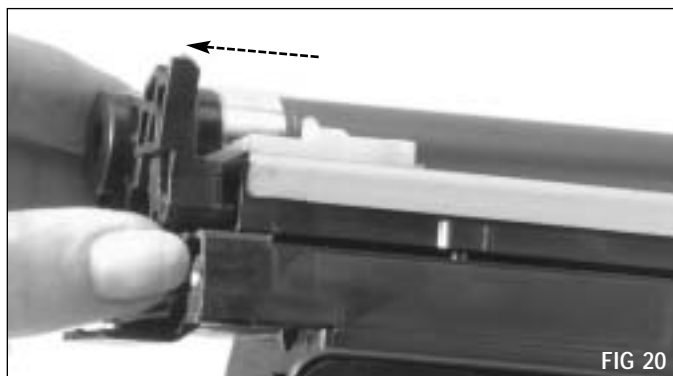

3. Remove the plastic mag roller bearing and store in a safe place for future use (FIG 22)

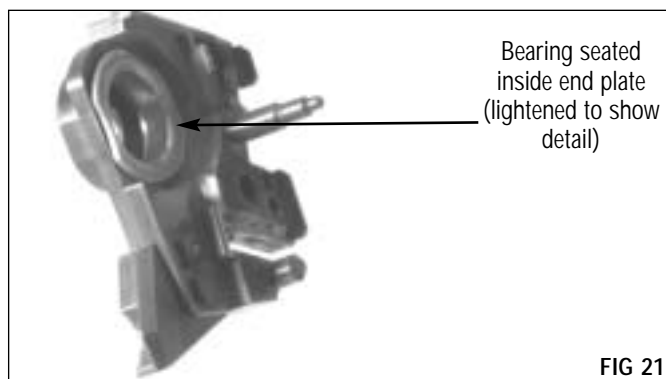

4. Remove the mag roller (FIG 22)

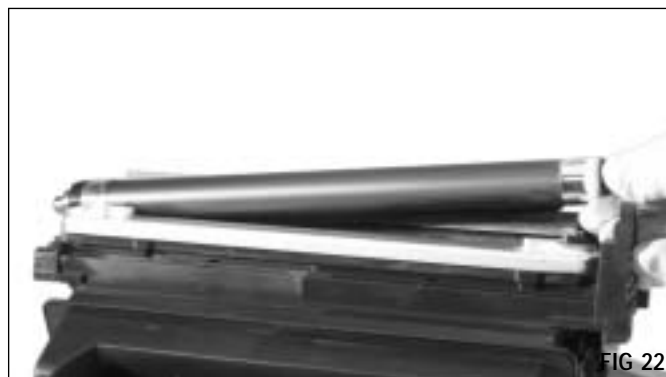

If the bearing remained on the mag roller shaft when the end plate was removed, slide the bearing off and set it aside (FIG 23).

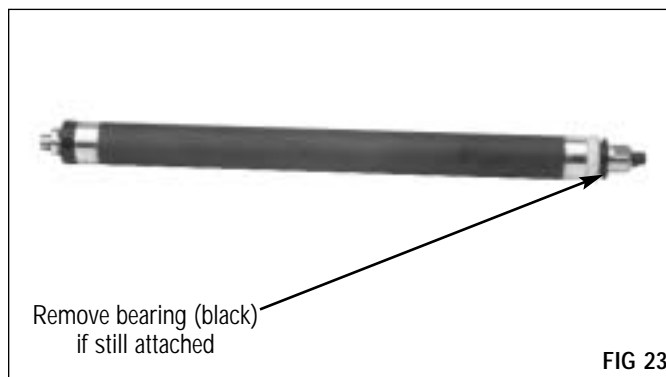

Remove the two air gap bushings and set the mag roller aside (FIG 24).

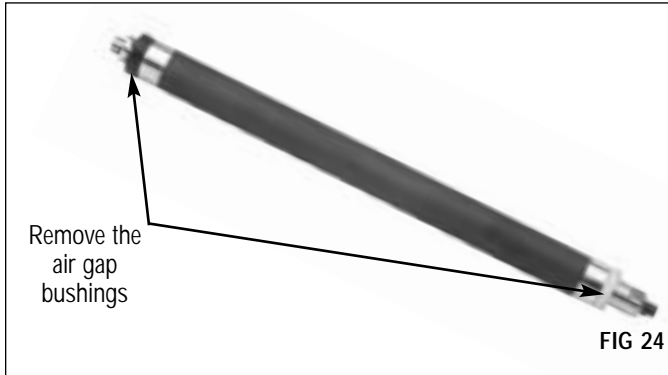

5. Remove the doctor blade

Remove the two screws that secure the doctor blade (FIG 25).

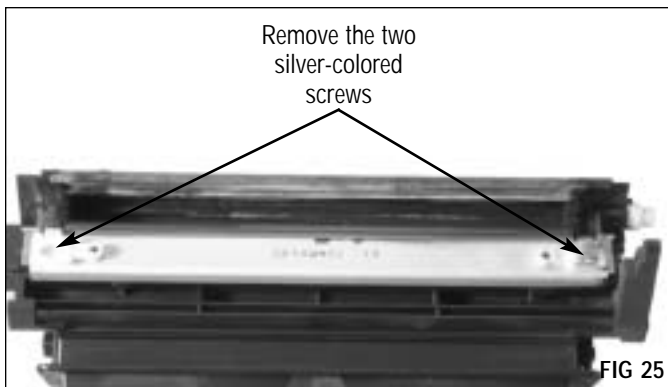

Remove the two white wipers and two clear shims (FIG 26).

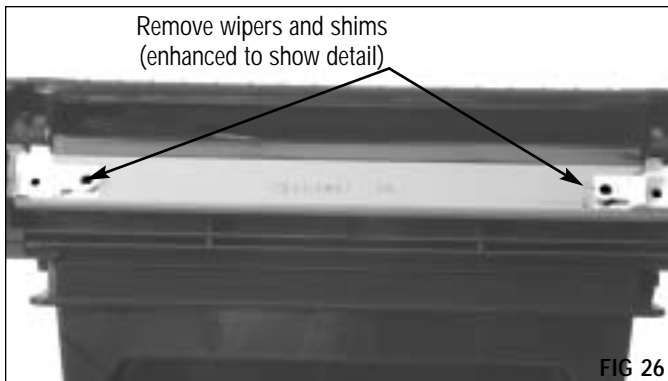

Lift the doctor blade from the housing and set it aside (FIG 27).

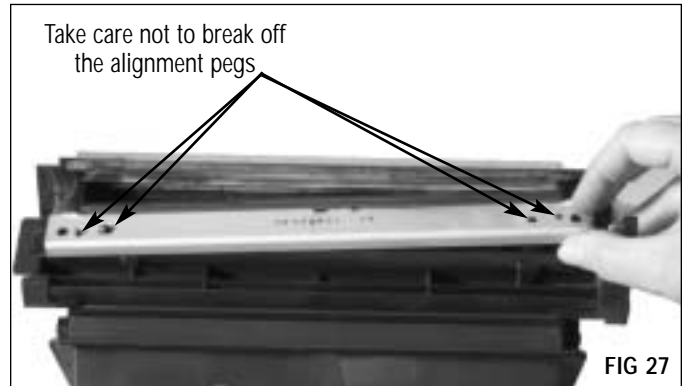

6. Split the hopper section

Note For optimum performance, split and seal the hopper/mag roller section. Use the HP8500 splitter tool (black cartridge) for splitting the HP4300 and 4200 hopper sections.

For detailed instructions, see SSS™ #493 "HP4300/4200 Splitting and Sealing Instructions", included with Static Control's HP4300/4200 Foam-type RapidSeal™.

After splitting, set the mag roller section aside.

7. Clean the hopper

Dump any remaining toner from the hopper and remove the hopper cap with needlenose pliers or a flat-blade screwdriver (FIG 28).

If using a flat-blade screwdriver, take care not to damage the cartridge housing or rim of the hopper cap, as toner leakage may result. In the event the cap is damaged, a replacement cap is available from Static Control.



Using ionized, dry, filtered, compressed air, carefully clean the hopper. Be sure to rotate the two toner agitators, carefully cleaning both sides of each (FIG 29).

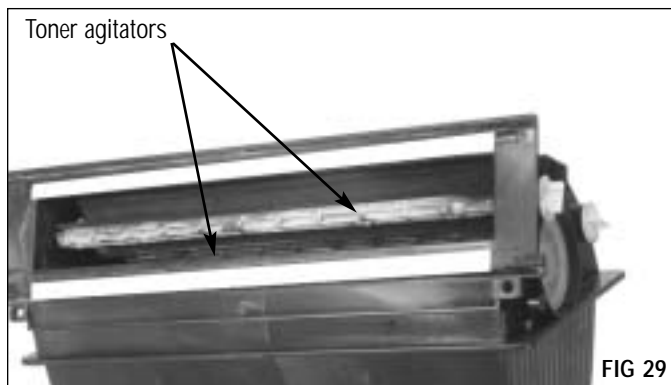

NOTE Using a Foam-Type RapidSeal™ for seal the HP4200 and HP4300 hoppers. For detailed instructions, see SSS™ #493 “HP4300/4200 Splitting and Sealing Instructions”.

8. Fill the hopper and replace the hopper cap

The HP9000 hopper cap is qualified for use in both the HP4200 & 4300 (FIG 30).





Reassembly of the Hopper/Mag Roller Section

1. Install the adhesive rail clip

Clean the area where the adhesive rail clip is to be attached with a lint-free cloth dampened with 91-99% isopropyl alcohol (FIG 31).

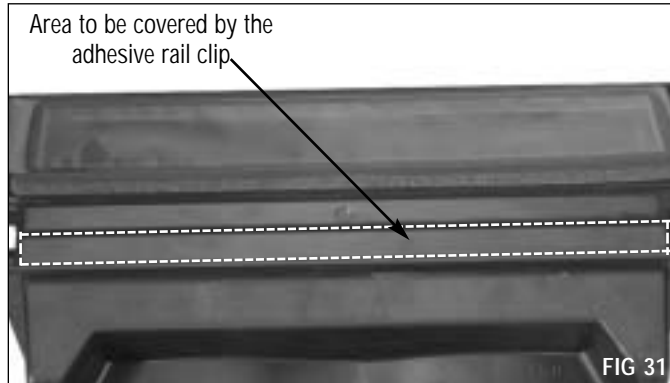

Remove the backing from the adhesive rail clip (FIG 32).

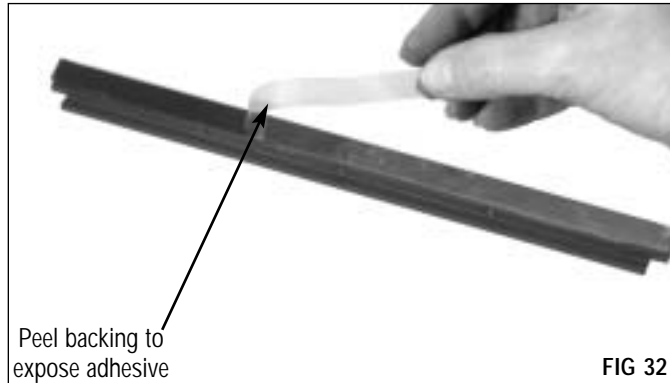

Place adhesive rail clip as shown. Ensure ends of adhesive rail clip are flush with hopper ends. Press firmly to activate adhesive (FIG 33).

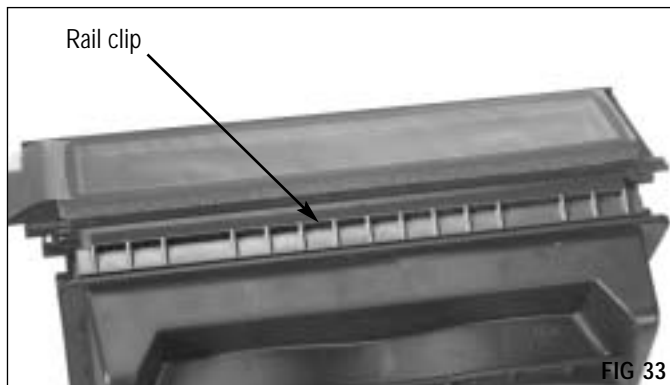

2. Clean the mag roller section

Caution:

There are two posts on the bottom of the mag roller section that must be removed (FIG 34). Use protective eyewear when removing these posts. Serious eye injury could result.

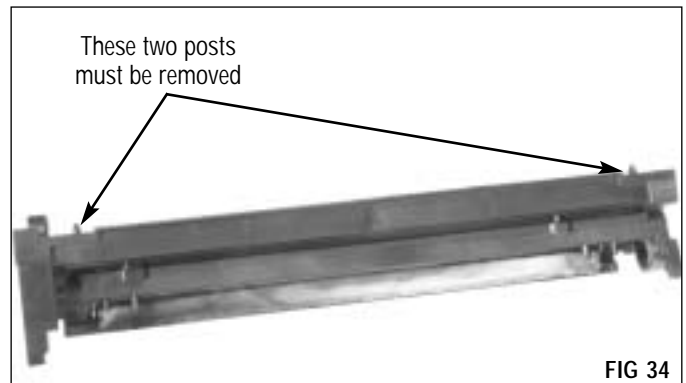

Using flush cutting pliers (side cutters), remove the plastic posts. Be sure to cut them flush with the housing (FIG 35).



Using ionized, dry, filtered, compressed air, clean and inspect the mag roller sealing blade, felts and foams (FIG 36). Replace damaged or toner-saturated components as needed (refer to SSS™ #653 and 526 for detailed replacement instructions).

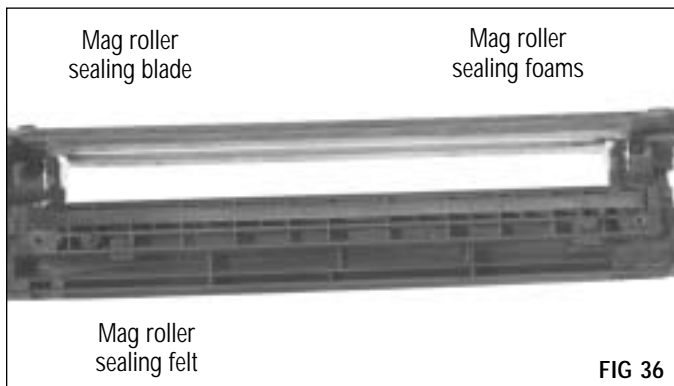

3. Join the hopper and mag roller sections

Fold the seal pull strip back over the hopper (FIG 37). The seal pull strip should be extended beyond the contact end of the hopper.

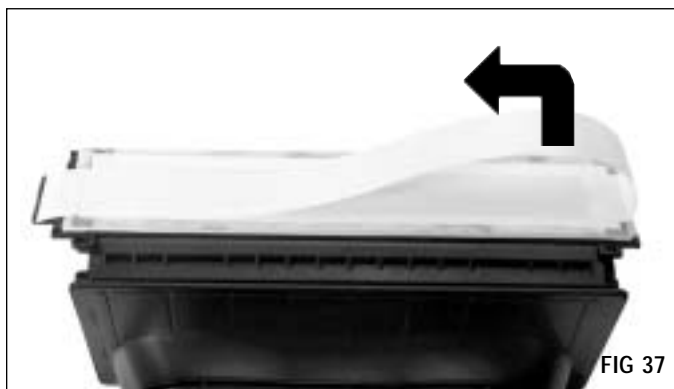

Turn the mag roller section over and place it at an approximate 45 degree angle to the hopper. Slide the lip of the mag roller section under the ledge of the rail clip (FIG 38). Check for proper seating by trying to slide the mag section back and forth (left to right). You should not be able to slide it off the hopper.

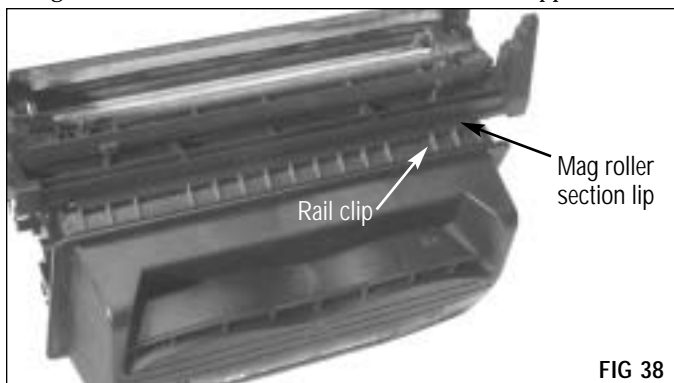

Position one short locking rail at one end of the hopper, with the short leg of the rail on the top of the mag section flange. Roll the rail down over the hopper flange and press into place (FIG 39).

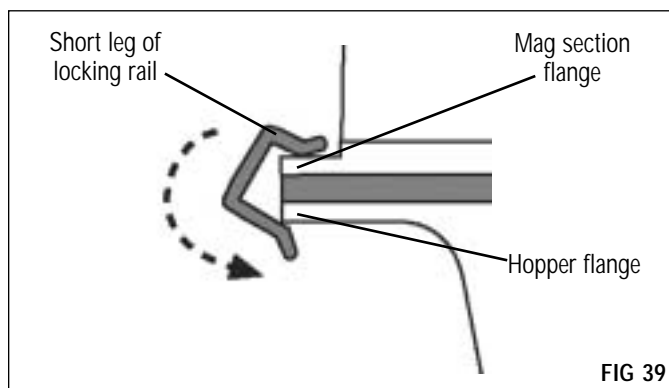

Install a second rail on the opposite end, and a third in the center (FIG 40). Inspect the hopper after installing the rails to ensure that no bowing has occurred.

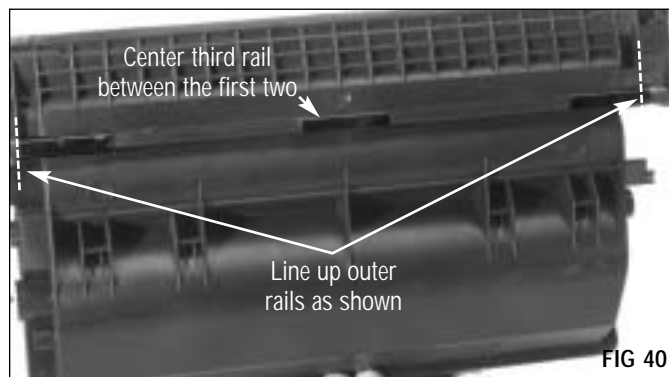

4. Install the doctor blade

Seat the doctor blade over the alignment posts (FIG 41).

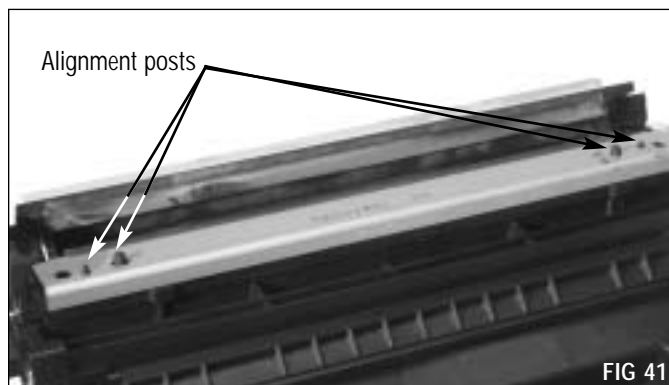

Install two shims and wipers on to the doctor blade; then, use the two silver Phillips screws secure the doctor blade, shims, and wipers (FIG 42).

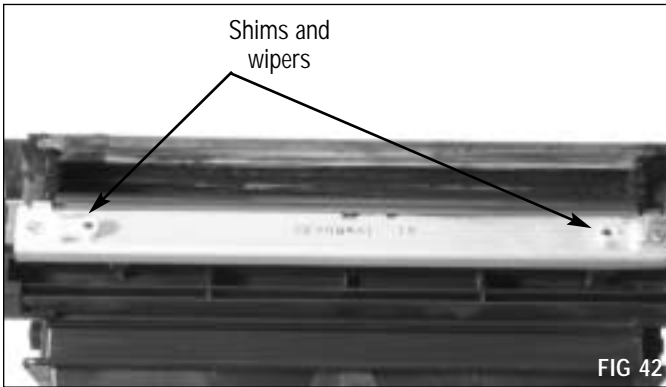

5. Replace the mag roller

After cleaning the mag roller install the mag roller bushings [black on contact end, white on drive gear end] (FIG 43). Because the bearings are keyed to the end plates, it is easier to install them in the plates and not directly onto the mag roller shaft at this time.

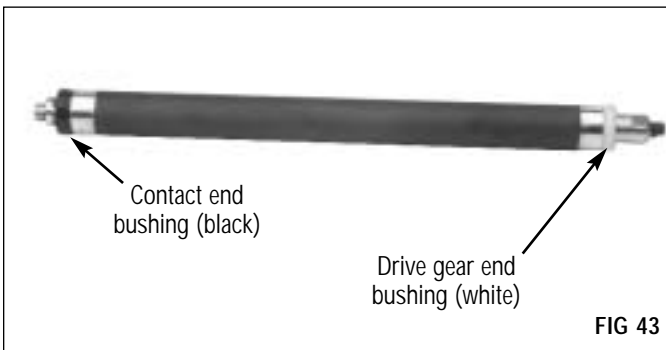

Using gloves or other protective material, seat the mag roller (FIG 44).

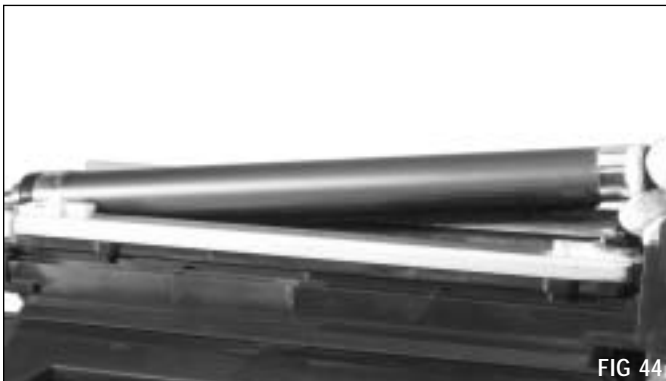

NOTE Make sure the bearing is seated properly before proceeding.

6. Replace the mag roller contact end plate

Make sure the bearing is seated in the end plate (FIG 45a) before seating the end plate (FIG 45b).

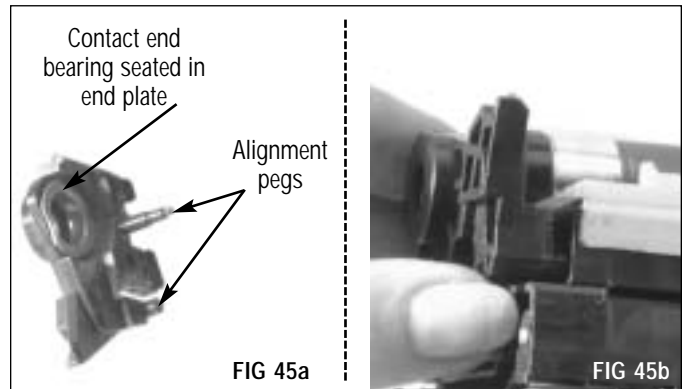

Replace the end plate screw, then the spring (FIG 46).

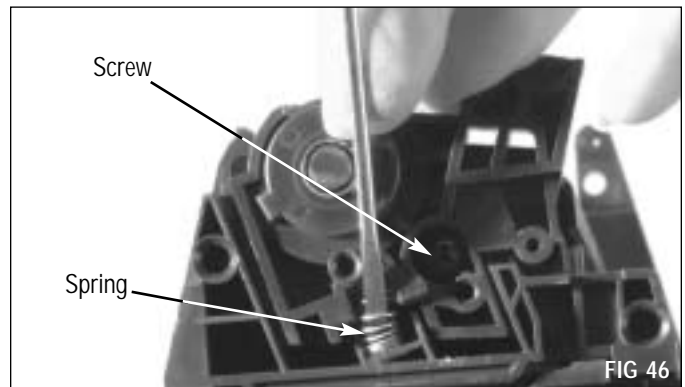

Install the toner low sensor bar (electrical contact pin) (FIG 47).

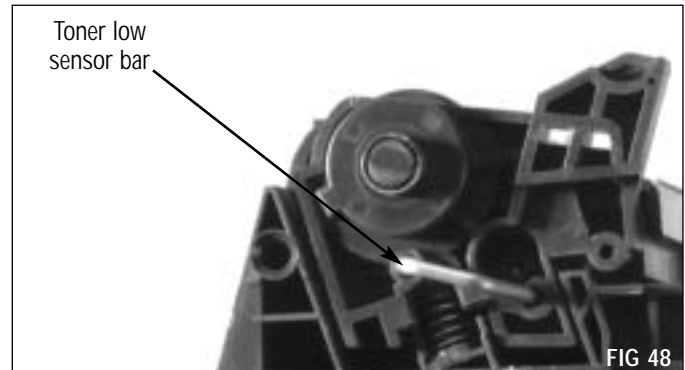

6. Replace the mag roller drive gear end plate

Make sure the bearing is secure in the end plate before positioning the alignment pegs and seating the drive gear end plate (FIG 49).

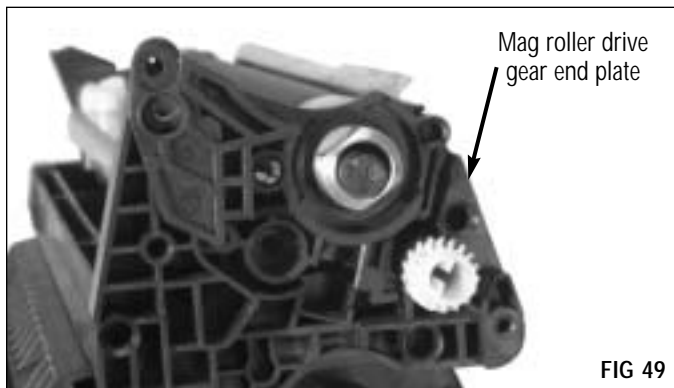

FIG 49

Install the mag roller drive gear housing support plate pin and screw (FIG 50).

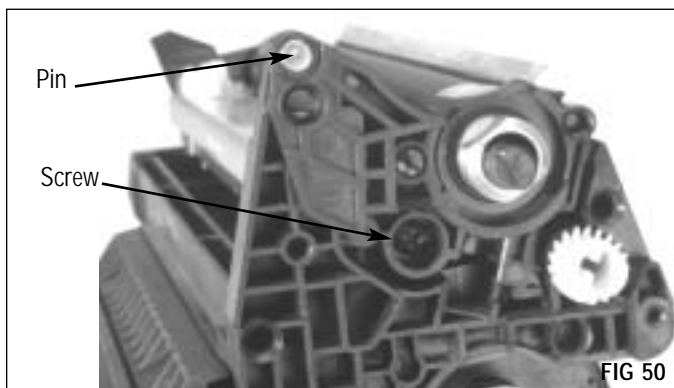

FIG 50

Install the mag roller drive gear housing support plate spring (FIG 51).

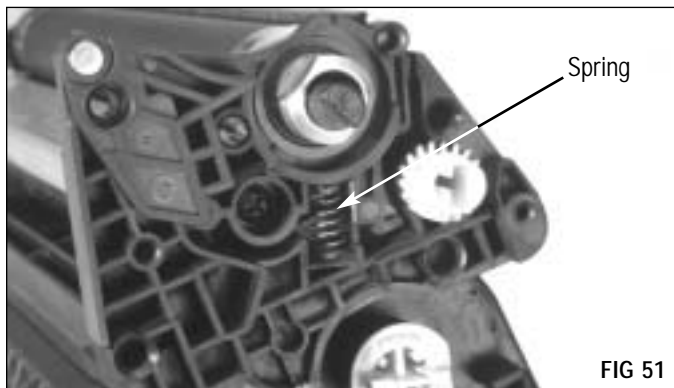

FIG 51

Install the mag roller drive gear (FIG 52).

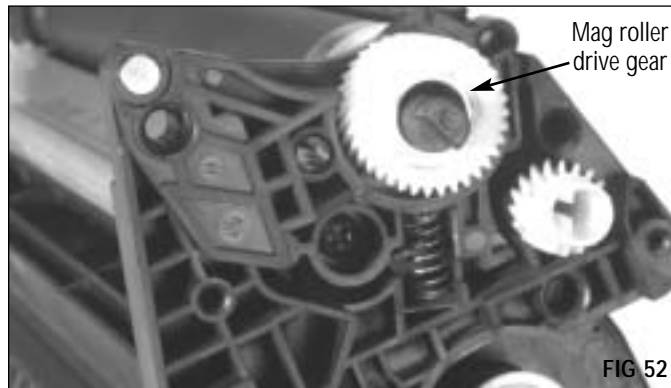

FIG 52

The mag roller drive gear cover is keyed to match end of magnetic developer roller magnet. Turn the contact end of the magnet to seat the drive gear cover (FIG 53).

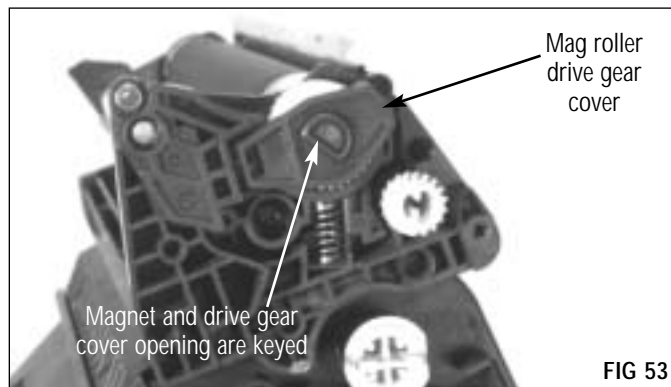
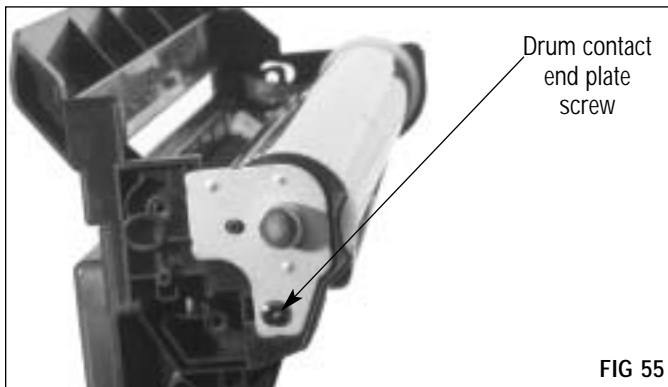

FIG 53

Disassembly of the Waste Bin

1. Remove the drum contact end plate

Remove the Phillips screw from the drum contact end plate (FIG 55).



Using a small flat-blade screwdriver in the locations shown, carefully ease the end plate away from the cartridge housing (FIG 56).

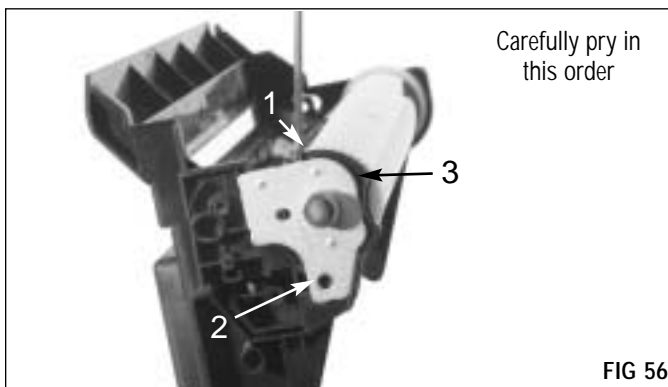

NOTE A short drum axle is attached to the drum contact end plate. When the plate is removed, the drum can fall from the cartridge housing.

Remove the drum contact end plate (FIG 57).

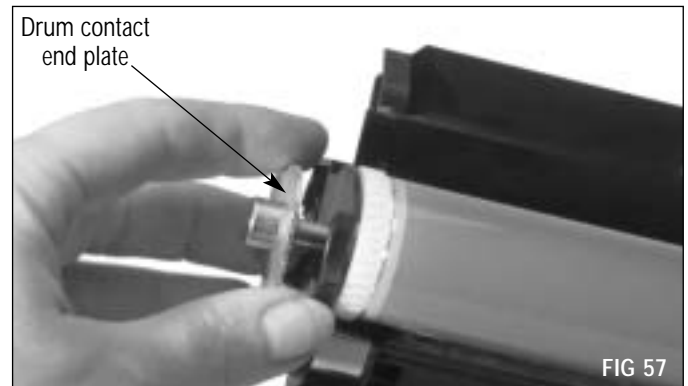

2. Remove the OPC drum

There is no need to remove the drive gear end plate (FIG 58) to remove the drum.

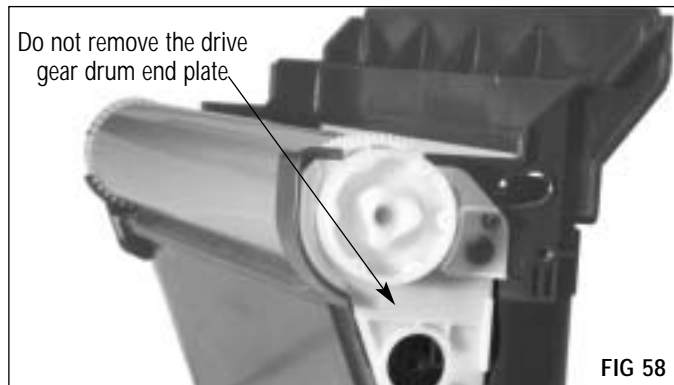

Remove the drum out of the housing by the contact end (small) helical gear (FIG 59). While supporting the large helical gear, lift up and away from the drive gear side of the housing.

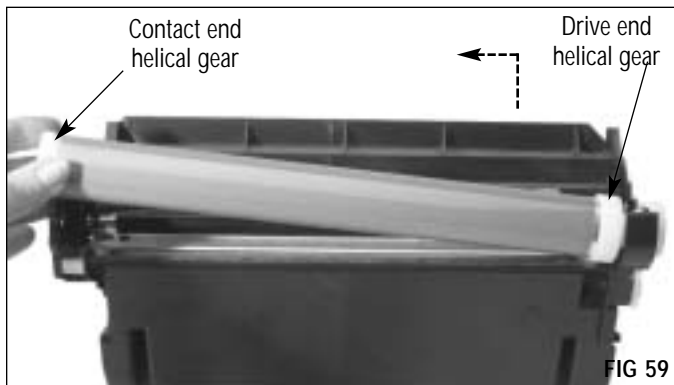

NOTE For best results, replace the OPC drum after the OEM cycle **and** after each remanufacturing cycle. A replacement drum with gears is available from Static Control.

When handling drums, handle by the gears only, or use clean latex gloves. Store it where it will be protected from light and impact damage.

NOTE Handle the PCR by the axle or use clean latex gloves. If you plan to reuse the PCR, store it on a flat uniform surface.

3. Remove the PCR

Using a pair of needlenose pliers, carefully pull each end of the PCR shaft toward you, freeing them from the PCR saddles (FIG 60a & 60b). Lift the PCR from the cartridge by the axle only, or use clean latex gloves .

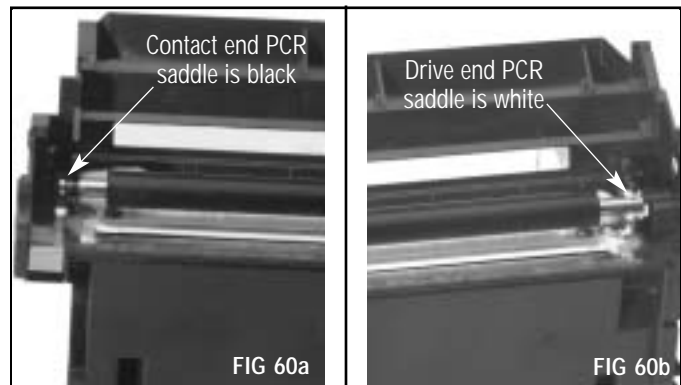

NOTE Do not stack PCRs, lay anything on top of them, wrap them with rubber bands, or touch the surface of the PCR with your bare fingers.

4. Remove the wiper blade sealing foam

NOTE If working with a virgin HP4200 or 4300 cartridge you will find, in place of a conventional wiper blade sealing foam, a line of hot-melt foam material at the back edge of the wiper blade (FIG 61). This foam must be removed in order to extract the wiper blade.

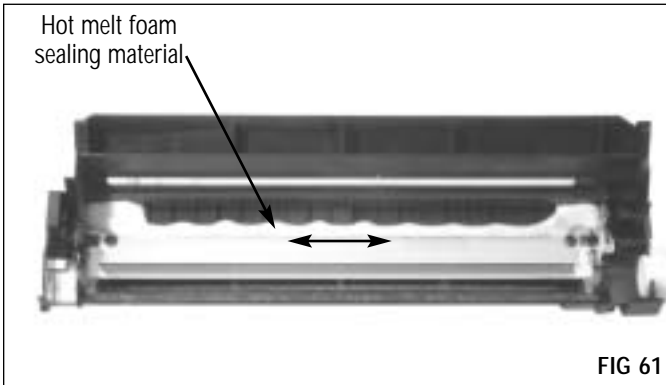

Using a felt/foam scraper tool to help lift the edges of the foam, remove the hot-melt material (which will be sticky) from the waste bin. Be sure to clean as much as possible from the corners (FIG 62).



**IF WORKING WITH A HP4200 CARTRIDGE,
SKIP TO STEP 6.**

5. Remove the wiper blade retaining ledge

HP4300 ONLY

NOTE If working with a virgin HP4300 cartridge you will find a retaining ledge at the back edge of the wiper blade. This ledge must be removed in order to extract the wiper blade (FIG 63). Refer to SSS™ #533 for detailed ledge removal instructions.

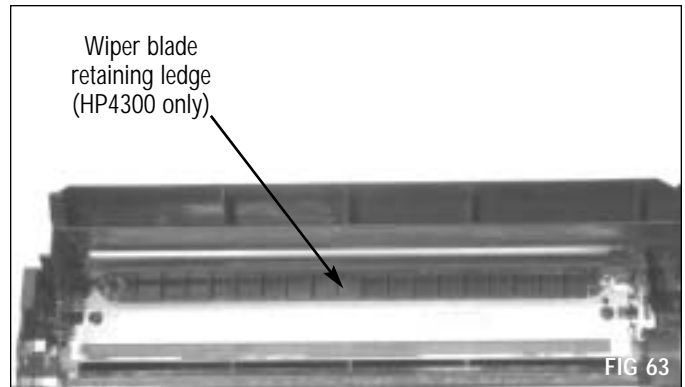

HP4300 ONLY

Insert the cartridge in the hopper fixture (FIG 64).

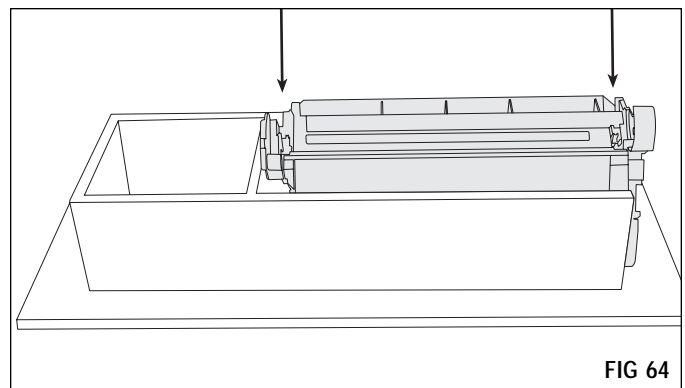

HP4300 ONLY

Static Control has developed a tool for safe, efficient removal of the wiper blade retaining ledge. This tool is to be connected to a rotary tool with a flex shaft attachment. In the following illustrations, a Freedom tool is shown.

HP4300 ONLY After removing the hot-melt sealing foam connect the cord of the wiper blade retaining ledge removal tool to a rotary tool equipped with a flex shaft attachment (FIG 65). The flex shaft and ledge removal tool connections are keyed (FIG 66a & 66b). Make sure they lock together securely .

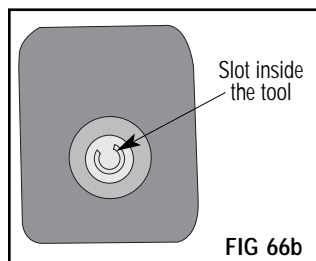
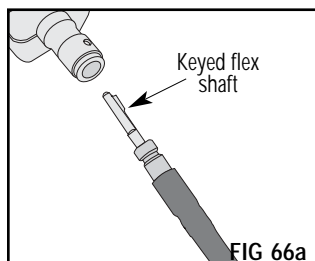
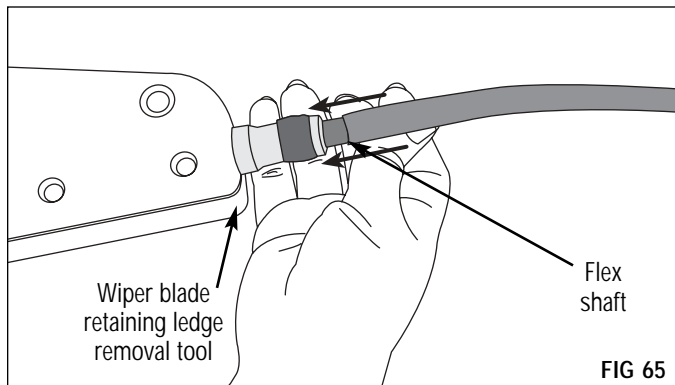

⚠ The use of protective eyewear is strongly recommended when removing the wiper blade retaining ledge. If adequate eye protection is not worn, serious eye injury may result.

NOTE It is recommended that the wiper blade screws be left in place during cutting of the wiper blade retaining ledge. The ledge removal tool is designed to slide over the wiper blade screws.

HP4300 ONLY Power up the rotary tool BEFORE placing it on the cartridge. Position the tool to the extreme right , aligning it with the flange of the cartridge housing (FIG 67).

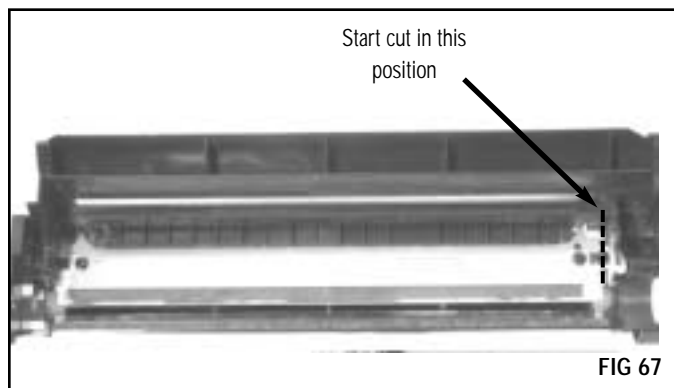

NOTE Stabilize the cartridge with one hand while applying firm pressure against the cartridge with the ledge removal tool. Be careful not to let the tool lift up when cutting over the raised ribs

HP4300 ONLY Begin cutting, moving the tool across the entire ledge of the cartridge in a right-to-left motion (FIG 68).

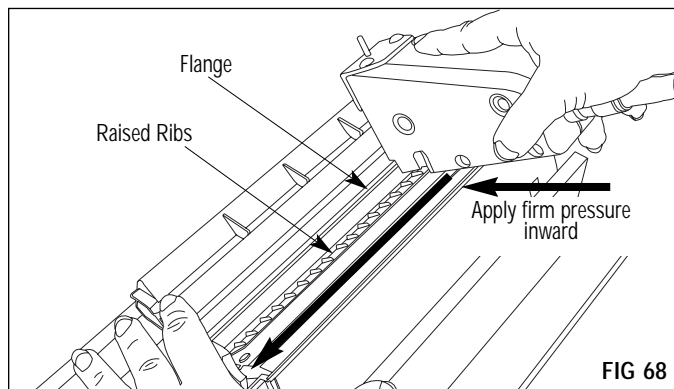

NOTE Be sure to remove all of the ledge material to prevent the wiper blade from binding on the cartridge housing during removal of the wiper blade.

HP4300 ONLY Remove the wiper blade retaining ledge from the housing (FIG 69). Insure that all ledge material is removed to prevent binding of the wiper blade. Clean the area of all loose debris.



6. Remove the wiper blade

Remove the two screws that secure the wiper blade (FIG 70).

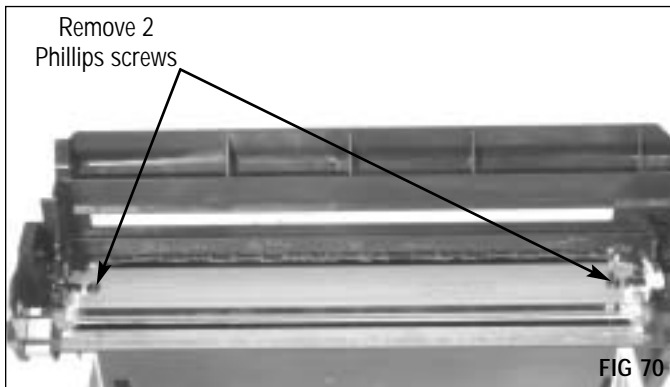

You may need to insert the end of a small flat-blade screwdriver to lift the back side of the blade from the waste bin housing (FIG 71).

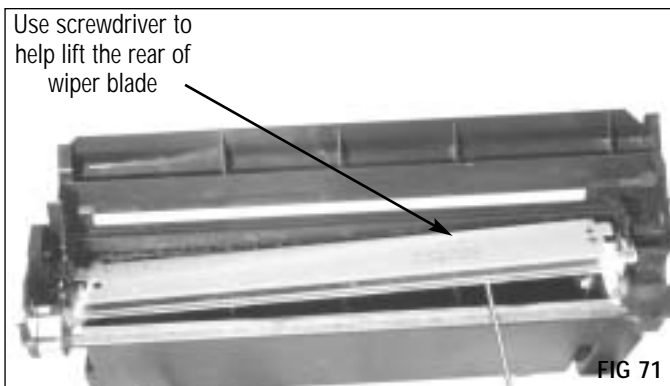

Remove the wiper blade from the waste bin housing (FIG 72).

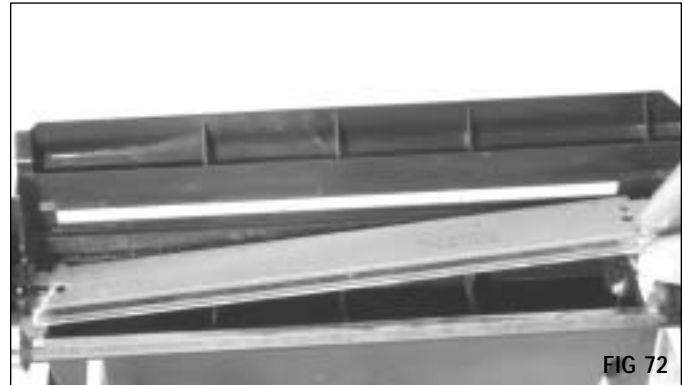

Using a cotton-tipped swab moistened with 91-99% isopropyl alcohol, remove any remaining hot-melt material from the waste bin.

7. Clean the waste bin

Dump any remaining toner from the waste bin and clean with ionized, dry, filtered, compressed air. Inspect the recovery blade, wiper blade sealing felts and foams for damage, and replace as needed (FIG 73).

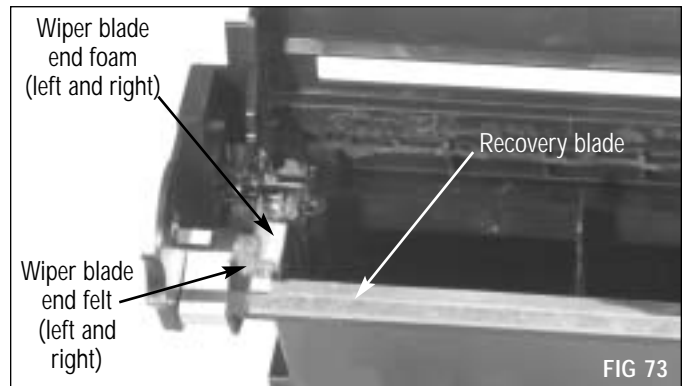



Reassembly of the Waste Bin

1. If necessary, clean, inspect and replace the recovery blade, wiper blade end felts and wiper blade end foams. For detailed instructions see SSS# 441 and SSS# 505.

HP4200 ONLY

Install the wiper blade sealing foam for the HP4200 cartridge see SSS™ #501 for complete instructions.

2. Install the wiper blade

Note A small amount of lubricant applied to the working edge of the wiper blade will help prevent blade “flip overs” during the first drum rotations.

Dip the edge of the wiper blade in a long, shallow trough containing Kynar® lubricating powder (FIG 74). Repeat once to insure even coverage. Tap once to remove excess Kynar® lubricating powder from the wiper blade.



FIG 74

Position the wiper blade over the alignment features, and secure with two Phillips screws (FIG 75a).

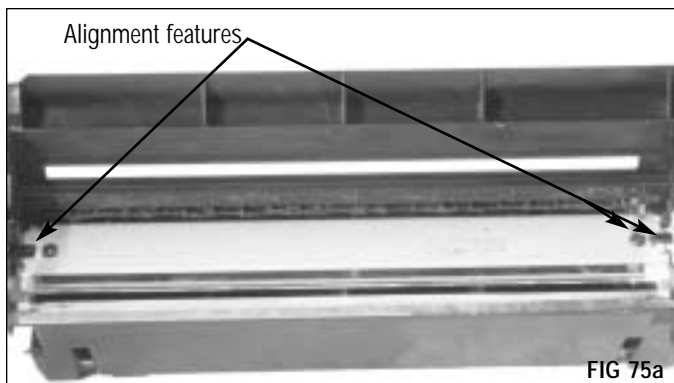

FIG 75a

HP4300 ONLY

Apply a large continuous bead of Adhesive Caulk (ADHCAULK), ensuring that the opening between the metal stamping of the Wiper Blade and the Waste Bin is completely sealed (FIG 75b).



FIG 75b

Note Remanufacturing the cartridge can continue as the Adhesive Caulk does not require a cure time in this application.

3. Replace the PCR

Clean the conductive PCR saddle (black, contact side of cartridge) with a cotton-tipped swab dampened with 91-99% isopropyl alcohol (FIG 76). Using the wooden end of the swab, apply a small amount of conductive cartridge lubricant to the inside of the PCR saddle.



FIG 76

Note If you are reusing the OEM PCR, clean the roller using a soft, lint-free cloth dampened with water. Gently wipe the PCR in one direction. Be careful not to pinch or dent the surface of the PCR.

Handle the PCR by the axle only or use clean latex gloves. Position the PCR and snap each end of the shaft into the PCR saddles (FIG 77).

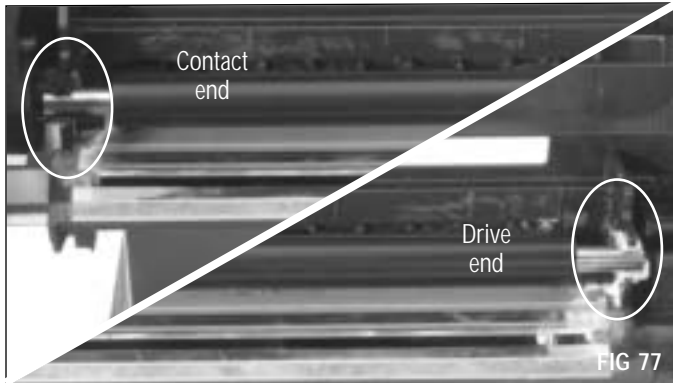

4. Replace the OPC drum

Note For best results, replace the OPC drum after the OEM cycle and after each remanufacturing cycle. A replacement drum with gears is available from Static Control.

Seat the drive gear side of the drum first by inserting the drum axle into the drum end plate (FIG 78), then seat the contact end.



5. Install the drum spur gear axle

Note Be sure the drum axle/contact plate is fully seated. The drum axle, when installed incorrectly, can result in print intervals on the right side of the page.

The axle features a step that mates with a corresponding inverted step in the waste bin housing (FIG 79).

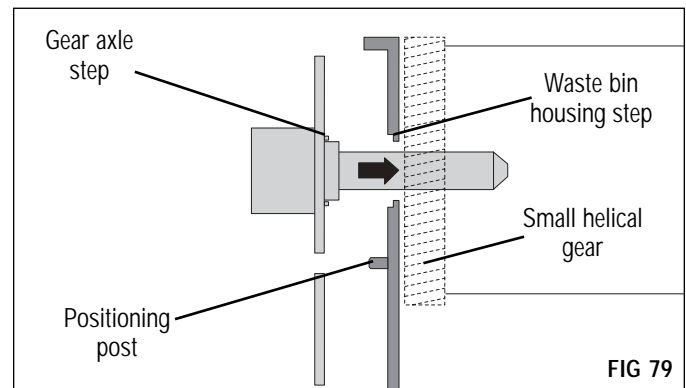

When the axle is correctly installed, a positioning post on the waste bin housing aligns in the center of a slot on the axle end plate (FIG 80).

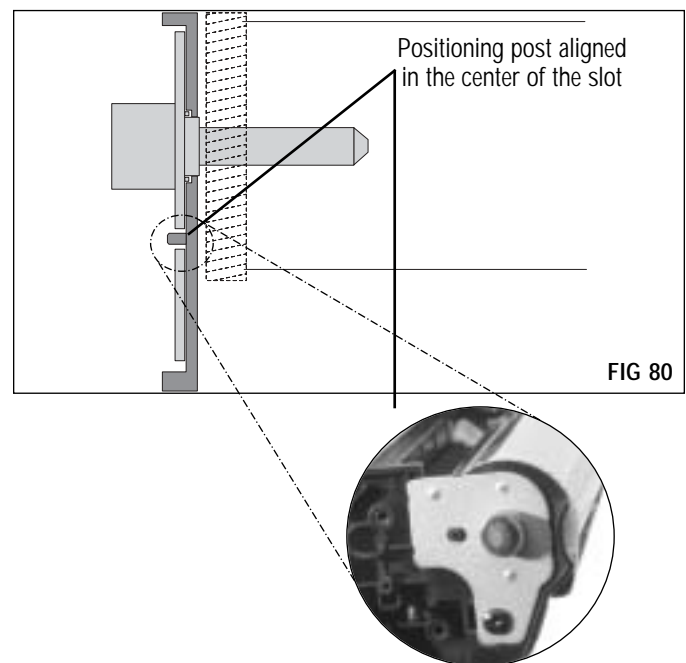

Secure the axle with one Phillips screw (FIG 81).

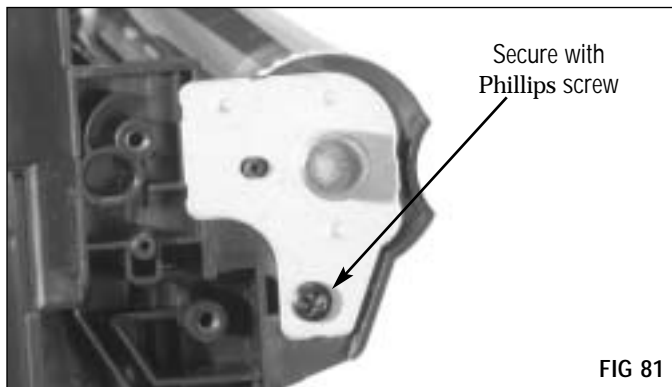

Note Ensure the drum is spinning freely and PCR is free of residual Kynar powder.

Reassembly of the Cartridge

1. Join the two halves

Seat the waste bin section on the hopper/mag roller section (FIG 82).



Note See SSS#590 *HP4300/4200 Contact End Plate Kit Instructions* for detailed instructions on end cap clean up and hopper preparation for end cap reassembly.

Note If the contact end plate does not seat properly, check the inside of the plate to insure that the weld recesses have been shaved smooth and level.

2. Attach the contact end plate

Position the contact end plate and pull the seal pull strip through the seal exit port (FIG 83). There is no need to lubricate the contacts inside the end plate.



Seat the contact end plate and secure with Phillips screws (FIG 84).

Note The screws that are used in place of the original welds are HP4200/4300 (HP43EPSCREW) screws. This is to prevent “bottoming out”, or going through the bottom of the screw boss inserted in the weld recesses.

Using standard cartridge screws could result in toner leakage, and/or could contaminate the toner supply. Shorter replacement screws are included with Static Control's end plate kit.

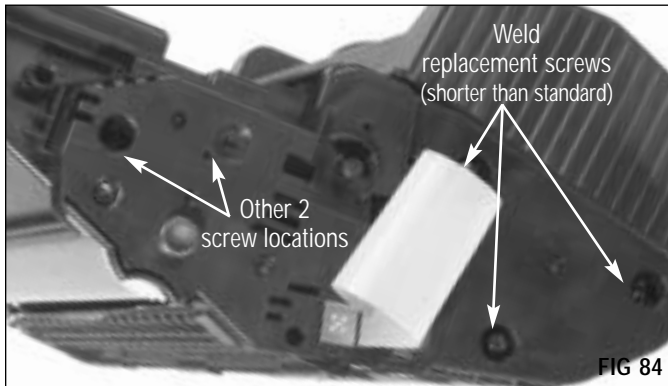

3. Attach the drive gear end plate

Install the drive gear end plate and secure with four Phillips screws (FIG 85).

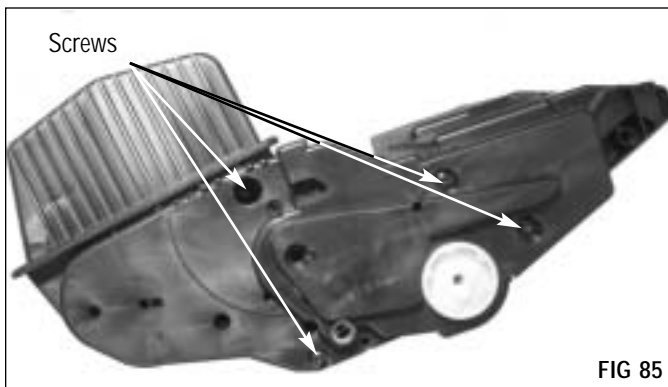

4. Post test cartridge.

For detailed instructions on post testing see SSS# 527 *HP4300/4200 Chip Solution*. Then return to step 5 to complete remanufacturing of cartridge.

5. Install the seal pull tab

Peel the backing from the pull tab to expose the adhesive (FIG 86). Do not contaminate the adhesive by touching it.



With the adhesive side down, center the tab on the top side of the seal pull strip (FIG 87).



The end of the strip should butt against the rail on the underside of the tab (FIG 88). Press to secure the tab to the pull strip.



6. Replace the drum shutter

The drum shutter arm and the hole on the drive gear side of the cartridge are keyed (FIG 89).



Insert the drive gear side shutter arm (FIG 90).



Insert the contact side shutter support bar (FIG 91).



Make sure the drum shutter actuator arm spring is in place and positioned as shown (FIG 92).



Make sure the drum shutter actuator arm is in place and positioned as shown on the drum shutter (FIG 93). Note that the drum shutter actuator arm is shown without the cartridge for detail purposes only. The shutter should be in place on the cartridge at this point.



Install the drum shutter actuator arm (FIG 94).



Using a hook tool, release the drum shutter actuator arm spring (FIG 95). Test the shutter to make sure it springs back into place when opened and released. Be careful not to damage the drum when doing so.

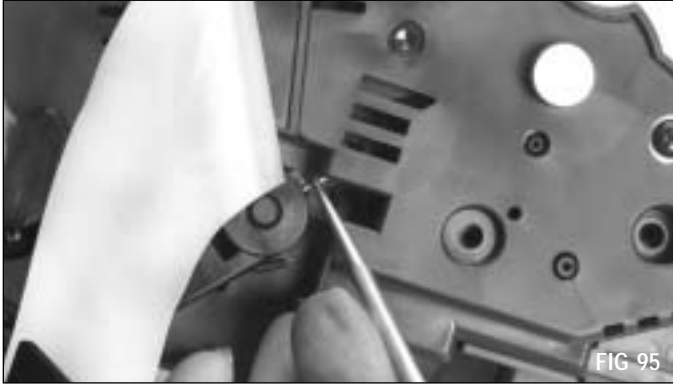

Note The cartridge must be post tested without a new chip and seal pull tab in place.

7. Install a new chip

For complete instructions, see SSS™ #527 (FIG 96).





Technology and Support You Can Rely On!

We realize that the success of your business directly affects the success of Static Control Components, Inc. It's no longer a matter of keeping up with your competition, but surpassing them. That is why we invest so much time and effort in the technology necessary for your business to address new market opportunities quickly, and with confidence.

Where monochrome once ruled the industry, color is now emerging and taking a foothold. It is our pledge to you, our customer, to do all we can to help you move into this new opportunity and others, as quickly and effortlessly as possible. We will continue to support monochrome markets, while building a comprehensive color technology library for your reference, along with products to support your growing business. Together we can build a partnership for a successful future.



STATIC CONTROL COMPONENTS, INC.

SCC Imaging Division

3010 Lee Avenue • PO Box 152 • Sanford, NC 27331
US/Can 800-488-2426 • US/Can Fax 800-488-2452
Int'l 919-774-3808 • Int'l Fax 919-774-1287
www.scc-inc.com

Static Control Components (Europe) Limited

Unit 32, Sutton's Business Park • Sutton's Park Avenue • Earley
Reading • Berkshire RG6 1AZ • United Kingdom
Tel +44 (0) 118 935 1888 • Fax +44 (0) 118 935 1177